



Geotextile Sand Filter

Alberta
Design & Installation Manual



Local Master Distributor:
Canwest Tanks & Ecological Systems
Surrey, BC
Tel: 604-580-3030
www.canwesttanks.com

Local Technical Representative:
BWD Engineering Inc.
Surrey, BC
Tel: 604-789-2204
www.bwdengineering.com

eljen
CORPORATION

Innovative Onsite Products & Solutions Since 1970

January 2024
www.eljen.com

Table of Contents

SUBJECT	PAGE
GLOSSARY OF TERMS	3
GSF SYSTEM DESCRIPTION	4
1.0 SYSTEM PRECONDITIONS	5
2.0 DESIGN AND INSTALLATION	6
3.0 FIELD SIZING	13
4.0 ADDITIONAL FIGURES	18
5.0 INSTALLATION GUIDELINES	20
6.0 DOSING DISTRIBUTION GUIDANCE	21
7.0 PRESSURE DISTRIBUTION GUIDANCE	21
8.0 SYSTEM VENTILATION	23
9.0 REQUIRED NOTES ON DESIGN PLANS	25
10.0 COMMERCIAL RECOMMENDATIONS AND GUIDANCE	26

GSF DRAWINGS AND TABLES

DRAWINGS

FIGURE 1: GSF SYSTEM OPERATION	4
FIGURE 2: TYPICAL A42 CROSS SECTION	6
FIGURE 3: VERTICAL SEPARATION DISTANCE	7
FIGURE 4: A42 MODULE END-TO-END SEPARATION FOR ALL APPLICATIONS	8
FIGURE 5: PLAN VIEW – EXAMPLE 1	14
FIGURE 6: SECTION VIEW – EXAMPLE 1	14
FIGURE 7: PLAN VIEW – EXAMPLE 2 – OPTION 1 TRENCHES	16
FIGURE 8: PLAN VIEW – EXAMPLE 2 - BED	17
FIGURE 9: PLAN VIEW – EXAMPLE 2 - ALTERNATIVE SOLUTION	17
FIGURE 10: SECTION VIEW – TRENCH SYSTEM – MULTIPLE LATERALS	18
FIGURE 11: SECTION VIEW – TRENCH SYSTEM – SLOPING SITE	18
FIGURE 12: SECTION VIEW – BED SYSTEM EXAMPLE	18
FIGURE 13: SECTION VIEW – 2 LATERAL BED SYSTEM; SLOPING SITE	19
FIGURE 14: RAISED BED (SAND MOUND) CROSS SECTION	19
FIGURE 15: RAISED BED ON SLOPE	19
FIGURE 16: PRESSURE PIPE PLACEMENT	21
FIGURE 17: PRESSURE CLEAN OUT	22
FIGURE 18: CONTOURED TRENCH PRESSURE DISTRIBUTION USING ORIFICE SHIELDS	22
FIGURE 19: AIR BY-PASS LINE DETAIL FOR VENTING OF PUMPED SYSTEMS (WHEN REQUIRED)	23
FIGURE 20: VENT LAYOUTS FOR LOW PRESSURE SYSTEMS	24
FIGURE 21: GSF WITH 4" VENT EXTENDED TO CONVENIENT LOCATION	24

TABLES

TABLE 1: SPECIFIED SAND SIEVE REQUIREMENTS	3
TABLE 2: STANDARD GSF A42 SIZING TABLE - RESIDENTIAL APPLICATIONS	10
TABLE 3: EFFLUENT SOIL LOADING RATES AND LINEAR LOADING RATES (METRIC)	11
TABLE 4: EFFLUENT SOIL LOADING RATES AND LINEAR LOADING RATES (IMP. GAL)	12

Glossary of Terms

A42 Module	120 cm x 60 cm x 18 cm; 48" x 24" x 7" (L x W x H)
Combined Treatment and Dispersal System	Combined Treatment and Dispersal System (CTDS) are passive onsite wastewater systems that combine treatment and dispersal of effluent in the same footprint.
Cover Fabric	The geotextile cover fabric (provided by manufacturer) that is placed over the GSF modules.
Geotextile Sand Filter	The Eljen Geotextile Sand Filter (GSF) Modules and the 15 cm (6 in) sand layer at the base and 15 cm (6 in) along the sides of the modules.
GSF Module	The individual module of a GSF system. The module is comprised of a cusped plastic core and corrugated geotextile fabric.
Infiltrative Surface Area	Is the area covered by the Eljen GSF system at the Point of Application.
Peak Wastewater Flow	As defined in the Alberta SOP 2021, is the flow rate used for sizing a wastewater system taking into account mass loading and mean daily flows. The estimated peak flow per A42 module that is used to size a GSF system using residential strength waste is 85 liters per day per module (18.7 IG/d/module).
Point of Application	The Point of Application is the interface surface(s) where the secondary treated effluent passes from the Eljen GSF System to the in-situ (or tertiary engineered media) receiving soils.
Pressure Distribution	Pressure Distribution is a method of achieving Uniform Distribution.
SOP 2021	The Alberta Private Sewage System Standard of Practice 2021 (Fourth Edition) as developed and published by the Safety Codes Council under the Safety Codes Act and is the rule in force as defined and limited by the Private Sewage Disposal Regulation A/R 264/2009.
Specified Sand	To ensure proper system operation, the system MUST be installed using ASTM C33 Sand. ASTM C33 sand will have less than 10% passing the #100 Sieve and less than 5% passing the # 200 sieve. Ask your material supplier for a sieve analysis to verify that your material meets the required specifications.

TABLE 1: SPECIFIED SAND SIEVE REQUIREMENTS

ASTM C33 SAND SPECIFICATION		
Sieve Size	Sieve Square Opening Size	Specification Percent Passing (Wet Sieve)
3/8 inch	9.52 mm	100
No. 4	4.76 mm	95 - 100
No. 8	2.38 mm	80 - 100
No. 16	1.19 mm	50 - 85
No. 30	590 µm	25 - 60
No. 50	297 µm	10 - 30
No. 100	149 µm	< 10
No. 200	75 µm	< 5

Note: Request a sieve analysis from your material supplier to ensure that the system sand meets the specification requirements listed above.

GSF System Description

The Eljen GSF Geotextile Sand Filter system is a cost-effective improvement over other septic treatment technologies. Comprised of a proprietary two-stage Bio-Matt™ treatment process, the geotextile modules apply a better-than-secondary treated effluent to the soil, increasing the soil's absorption rate. The result is superior treatment in a smaller soil absorption area.

In Alberta under the Private Sewage Systems Standard of Practice 2021, the Eljen GSF is a secondary treatment Level 4-DI system. Combined Treatment and Dispersal Systems are not currently defined in the AB SOP 2021, but the Eljen GSF is authorized for use under a standard variance application.

In Alberta the Eljen GSF is configured for use in systems using full uniform distribution.

Primary Treatment Zone

- Perforated pipe is centered above the GSF module to distribute septic effluent over and into corrugations created by the cusped core of the geotextile module.
- Septic effluent is filtered through the Bio-Matt fabric. The module's unique design provides increased surface area for biological treatment that greatly exceeds the module's footprint.
- Open air channels within the module support aerobic bacterial growth on the module's geotextile fabric interface, surpassing the surface area required for traditional absorption systems.
- An anti-siltation geotextile fabric covers the top and sides of the GSF module and protects the Specified Sand and soil from clogging, while maintaining effluent storage within the module.

Secondary Treatment Zone

- Effluent drips into the Specified Sand layer and supports unsaturated flow into the native soil. This Specified Sand/soil interface maintains soil structure, thereby maximizing the available absorption interface in the native soil. The Specified Sand supports nitrification of the effluent, which reduces oxygen demand in the soil, thus minimizing soil clogging from anaerobic bacteria.
- The Specified Sand layer also protects the soil from compaction and helps maintain cracks and crevices in the soil. This preserves the soil's natural infiltration capacity, which is especially important in finer textured soils, where these large channels are critical for long-term performance.
- Native soil provides final filtration and allows for groundwater recharge.

FIGURE 1: GSF SYSTEM OPERATION

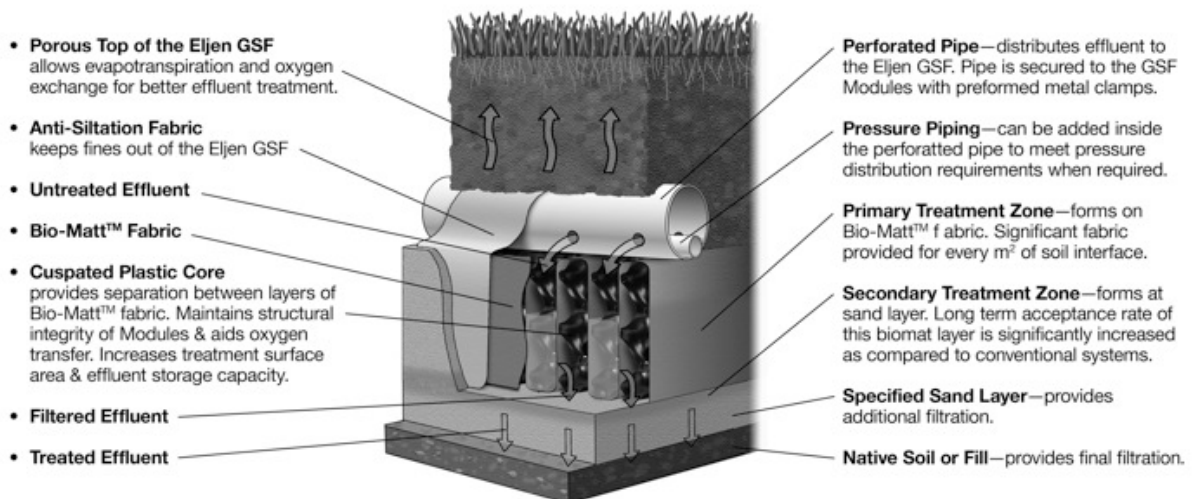

1.0 System Preconditions

1.1 REQUIREMENTS: GSF systems must meet the Alberta SOP 2021, local rules and regulations, and the steps outlined in this manual. This Manual is intended to comply completely within the Alberta SOP 2021. For any system outside the SOP 2021, including commercial systems, please contact BWD Engineering at 604-789-2204 or Eljen Corporation and 800-444-1359 for more information on sampling devices and techniques that can be used with the GSF system.

1.2 WATER CONDITIONERS: Water conditioners can adversely affect septic tank treatment and add to the hydraulic load of the effluent disposal area. **Discharge residential conditioner backwash from these devices shall be into a separate alternative disposal system.**

1.3 GARBAGE DISPOSALS: Garbage Disposal units (garburators) increase the organic loading to the system. If the owner wishes to use a garburator then the requirements of SOP 2021 must be followed including increasing the number of Eljen GSF modules by 35%. Design Drawings and Owners Operation & Maintenance manual must include a note that clearly indicates **“Garbage Disposals ARE or ARE NOT allowed to be used with this system.”**

NOTE: Eljen strongly encourages the use of septic tank outlet effluent filters on all systems. Filters with higher filtration are recommended for systems with garbage disposals.

1.4 ADDITIONAL FACTORS EFFECTING RESIDENTIAL SYSTEM SIZE: Homes with an expected higher than normal water use should increase septic tank capacity and/or utilize multiple compartment tanks. Increasing the minimum effluent disposal area should also be considered.

Factors that may affect system size:

- Luxury homes, which may include Jacuzzi style tubs, or other high use fixtures.
- Homes with known higher than normal occupancy.
- Homes with water conditioner backwash and high efficiency furnace condensate. (Diversion from septic tank required).

Designers should use discretion when multiple additional factors are involved. Increase size in proportion to excess flow.

1.5 SYSTEM PROHIBITED AREAS: All vehicular traffic is prohibited over the GSF system. This is due to the compaction of material required to support traffic loading. This compaction greatly diminishes absorption below the GSF system and diminishes the void spaces that naturally exist in soils which provide oxygen transfer to the GSF system.

1.6 CONDENSATE FROM HIGH-EFFICIENCY FURNACE: Condensate from High-Efficiency Furnaces can adversely affect septic tank treatment and add to hydraulic load of the GSF system. **Condensate discharge from these devices shall be directed to a separate alternative disposal system.**

2.0 Design and Installation

FIGURE 2: TYPICAL A42 CROSS SECTION

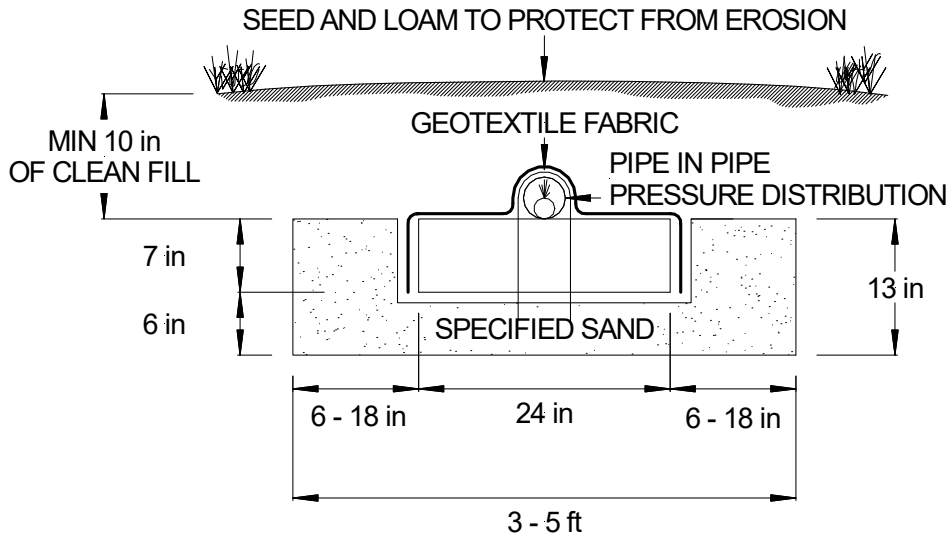

A42 MODULE (L x W x H) 120 CM x 60 CM x 18 CM (48 IN x 24 IN x 7 IN)

All systems are required to have a minimum of:

- 15 cm (6 in) of Specified Sand is at the edges of the GSF module.
- 15 cm (6 in) of Specified Sand is at the beginning and end of each GSF Row.
- 15 cm (6 in) of Specified Sand is directly below the GSF module.
- Minimum 25 cm (10 in) of cover above the module.

2.0 Design and Installation

2.1 SEPTIC TANKS: The Alberta SOP 2021 septic tank requirements are to be followed. Dual compartment tanks are recommended for all systems. Eljen supports this practice as it helps to promote long system life by reducing TSS and BOD to the effluent disposal area. Effluent filters are also strongly encouraged.

2.2 SEPTIC TANK FILTERS: Septic tank effluent filters are **STRONGLY ENCOURAGED** on the outlet end of septic tank. Filter manufacturers require that filters be cleaned from time to time. Ask your installer or designer for specific cleaning requirements based on the type or make of the filter installed. Eljen requires the septic tank to be pumped every three years or as needed which would be a good time to check and conduct filter maintenance.

2.0 Design and Installation

2.3 VERTICAL SEPARATION TO LIMITING LAYER: The required VS is defined for all systems in the appropriate section in Part 8 of the SOP 2021.

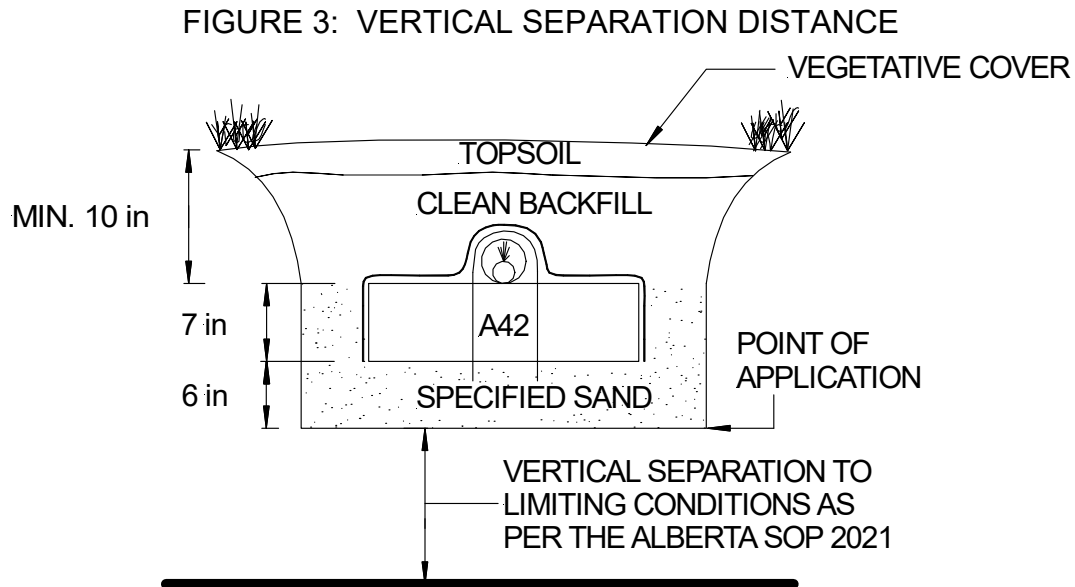

2.4 SPECIFIED SAND SPECIFICATION FOR GSF SYSTEMS: The first 15 cm (6 in) of Specified Sand immediately under, between rows and around the perimeter of the GSF system must be **ASTM C33 WASHED CONCRETE SAND WITH LESS THAN 10% PASSING A #100 SIEVE AND LESS THAN 5% PASSING A #200 SIEVE**. Please place a prominent note to this effect on each design drawing. See page 6 for Specified Sand requirements.

2.5 PLACING GSF MODULES: Each module is placed with the white paint strip up. The “painted stripe” on the GSF modules indicates the top of the module and is not intended to indicate the location of the distribution pipe. With the painted stripe facing up, all rows of GSF modules are set level, end to end on the Specified Sand layer.

Beds have a minimum spacing of 30 cm (12 in) between parallel rows. Systems with up to 15 cm (6 in) elevation drop between adjacent module rows use 30 cm (12 in) minimum spacing. If over 15 cm (6 in) drop, use two times the elevation drop as minimum spacing between module rows. Rows can be separated by up to 90 cm (3 ft) to increase effective infiltrative area (widthwise). See Figures 8 and 12 to 16.

No mechanical connection is required between modules. Modules may be spaced up to 90 cm (3 ft) end-to-end and edge-to-edge along the distribution lateral to increase effective infiltrative area (lengthwise). See Figures 4, 7, 8, 9, and 12.

2.0 Design and Installation

FIGURE 4: A42 MODULE END-TO-END SEPARATION FOR ALL APPLICATIONS

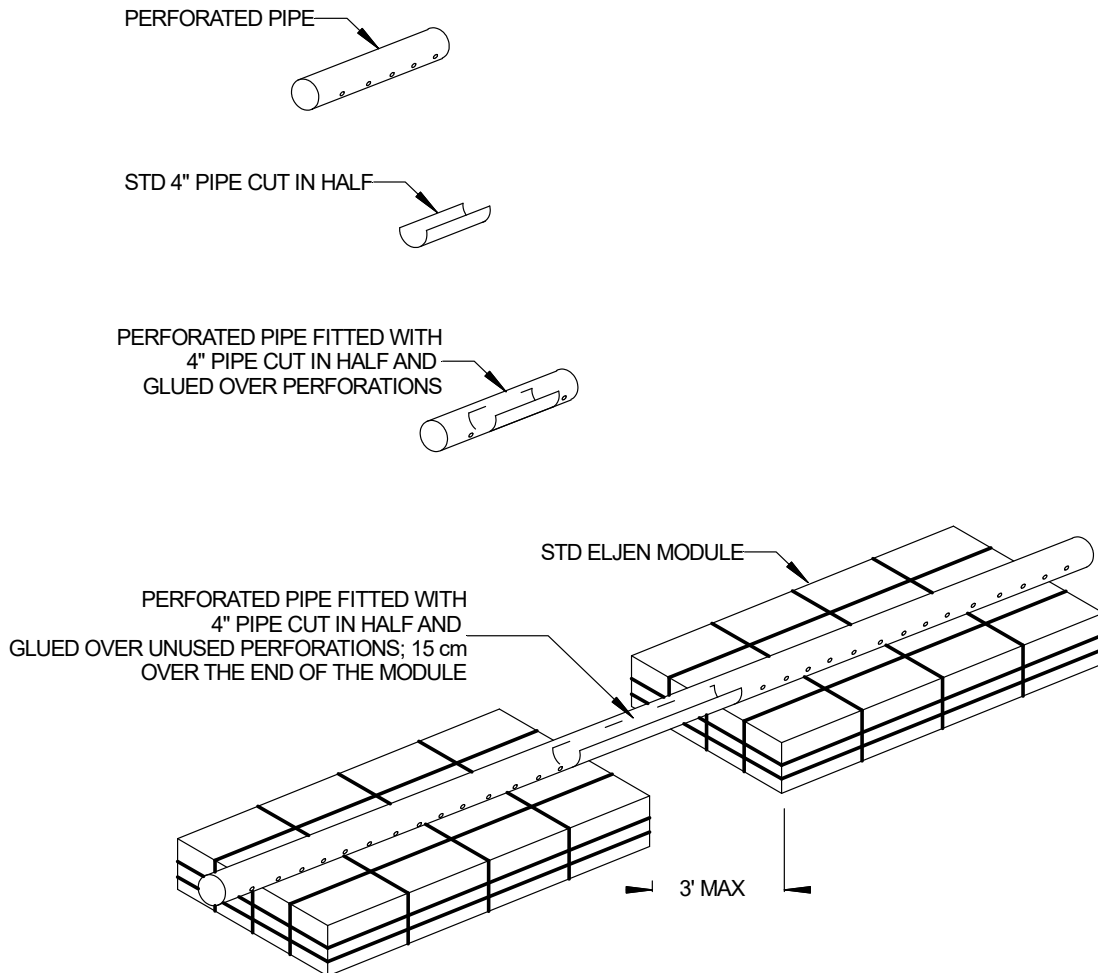

2.6 DISTRIBUTION: Pressure distribution is required when using the GSF System. Two delivery methods are acceptable. Orifice shields are placed over a SCH 40 pipe, one per module. A second delivery method is also permissible. Using approved perforated pipe; a pressure manifold is placed inside the distribution pipe. Section 7 of this manual goes into details of how to construct the distribution network. All piping must meet provincial and local regulations.

2.7 COVER FABRIC: Geotextile cover fabric is provided by Eljen Corporation for all GSF systems. It is placed over the top and sides of the module rows to prevent long term siltation and failure. **Cover fabric substitution is not allowed.** Fabric should drape vertically over the pipe and must *not* block holes in the distribution pipe or be stretched from the top of the pipe to the outside edge of the modules. "Tenting" will cause undue stress on fabric and pipe.

Note: If modules are spaced end-to-end, fabric must be cut and allowed to drape over and protect the ends of each spaced module. A continuous run of geotextile fabric is not allowed for these applications. Stipulate end-to-end spacing to receive adequate fabric when ordering.

2.8 SYSTEM VENTING: All systems require sufficient oxygen supply to the effluent dispersal area to maintain proper long-term effluent treatment. Therefore, the following situations require venting at the far end of the system:

- Any system with more than 45 cm (18 in) of total cover as measured from the top of the module.
- Areas subject to compaction.

2.0 Design and Installation

2.9 BACKFILL & FINISH GRADING: Carefully place backfill over the modules, followed by topsoil to complete a total minimum depth of 25 cm (10 in) as measured from the top of the distribution pipe. Systems with total cover that exceeds 45 cm (18 in) as measured from the top of the module shall be vented per Section 8. Backfill material should be a well-graded sandy loam fill; clean, porous, and devoid of rocks larger than 5 cm (2 in). Divert surface runoff from the effluent disposal area. Finish grade to prevent surface ponding. Seed loam to protect from erosion.

2.10 BACKFILL MATERIAL FOR RAISED SYSTEMS: Fill material below the Specified Sand for raised bed systems must be per the SOP 2021. Fill must be consolidated in lifts to prevent differential settling.

2.11 POINT OF APPLICATION: The Point of Application is the interface surface(s) where the secondary treated effluent passes from the Eljen GSF System to the in-situ (or tertiary engineered media) receiving soils. See Figure 3.

2.12 SYSTEM GEOMETRY: In general, design systems long and narrow along site contours to minimize groundwater mounding especially in poorly drained low permeability soils. If possible, design level systems with equal number of modules per row.

LEVEL SYSTEMS: Design level in-ground or raised systems with 30 cm minimum and up to 90 cm maximum spacing between module rows, and from 0 to 90 cm spacing end to end. The system specified sand, GSF modules, and distribution pipes are installed level at their design elevations.

SLOPED SYSTEMS: Design level in-ground or raised systems with 30 cm minimum and up to 90 cm maximum spacing between module rows and 0-90 cm spacing end to end. Systems with up to 15 cm elevation drop between adjacent module rows use 30 cm minimum spacing. If over 15 cm drop, use two times the elevation drop as minimum spacing between module rows. The system specified sand, GSF modules, and distribution pipes are installed level at their design elevations along the site contours.

2.13 SYSTEM SIZING: The total infiltrative surface area required is site specific and determined by the Peak Daily Wastewater Flow and soils analysis as specified in the SOP 2021.

The GSF system is a Level 4-DI Combined Treatment and Dispersal System thus requiring reduced field size and reduced vertical separation compared to that of a standard Level 1 stone and pipe system or chamber system.

- The number of GSF modules required (See 2.16) typically fits the required infiltrative surface area and can be configured to properly cover any shape required. This is the same for trench, bed or mound systems.
- In beds and mounds, a minimum of 30 cm separation is required between parallel rows of GSF modules to utilize sidewall infiltration area.
- Maximum edge-to-edge and end-to-end separation for Modules in all applications is 90 cm (3 ft).

2.14 NUMBER OF GSF MODULES REQUIRED: Each Eljen GSF A42 is designed to a standard loading for residential strength effluent of 85 liters per day per module (18.7 IG/d/module) for trenches and beds and mound systems.

Table 2 indicates the minimum number of GSF A42 modules required for standard homes as listed in the SPM where trench, bed and mound systems are applicable. For all systems with unlisted Peak Wastewater Flows of residential effluent the number of GSF A42 modules is calculated by dividing the selected Peak Wastewater Flow in Liters/day by 85 L/day/module.

- For trench, bed and mound sizing and configuration drawings see Sections 3 and 4 of this manual.
- For information on commercial systems see Section 10.

2.0 Design and Installation

2.15 SAMPLING: Contact BWD Engineering at 604-789-2204 or Eljen Corporation and 800-444-1359 for more information on sampling devices and techniques that can be used with the GSF system.

2.16 SYSTEM COMPONENT SIZING:

TABLE 2: STANDARD GSF A42 SIZING TABLE - RESIDENTIAL APPLICATIONS

Bedrooms					
1	2	3	4	5	6
Minimum Peak Daily Wastewater Flow Liters/Day (Imp. Gal/day)					
680 (150)	1360 (300)	1530 (337.5)	2040 (450)	2550 (562.5)	3060 (675)
Recommended Minimum Number of Modules					
10	14	18	24	30	36

Table 2 shows the minimum number of A42 modules required for residential systems up to 6 bedrooms. For other flow rates and number of bedrooms not shown in Table 2, divide the Peak Wastewater Flow by 85 L/d/module (18.7 IG/d/module) and round up to the next whole number. For residential homes a minimum of 6 modules per bedroom is required. If the Peak Wastewater Flow divided by 85 L/d/module (18.7 IG/d/module) equals less than 6 modules per bedroom, round up to the minimum number of A42 modules required per bedroom.

Flows indicated in Table 2 are the minimum per the SOP 2021 and do not include Fixture Units that may require additional capacity. For large or non-residential applications, see Section 10 Commercial Systems and please contact the Eljen Technical Representative, BWD Engineering Inc.

For applications where very large infrequent surging is anticipated, the Eljen GSF can manage the additional flows and remain within treatment specifications for a significant duration. To ensure the correct number of modules are specified and proper soil conditions are assessed, please contact BWD Engineering at 604-789-2204 or Eljen Corporation and 800-444-1359 for more information on sampling devices and techniques that can be used with the GSF system.

2.17 INFILTRATIVE SURFACE MODULE SIZING: To cover the larger infiltrative surface areas required by slower soils, for multi row systems, increase the edge-to-edge separation between runs to a maximum of 90 cm (3 ft). In a single row system, the Eljen GSF system width can be increased by 60 cm (2 ft) for a total width of 150 cm (5 ft).

For all systems, the Eljen GSF modules can also be separated by up to 90 cm (3 ft) end-to-end to increase infiltrative surface area or contour length without additional modules. For very slow soils, additional modules may be required.

The smallest footprint per module is: 0.9 m X 1.2 m or 1.1 m² (3 ft X 4 ft = 12 ft²)

The largest footprint per module is: 1.5 m X 2.1 m or 3.2 m² (5 ft X 7 ft = 35 ft²)

The Shortest length per module is: 1.2 m (4 ft)

The Longest length per module is: 2.1 m (7 ft)

For assistance with very large, unusual shaped, or multiple infiltrative surface areas, please contact the Eljen Technical Representative, BWD Engineering Inc.

2.0 Design and Installation

2.18 INFILTRATIVE SURFACE SIZING:

TABLE 3: EFFLUENT SOIL LOADING RATES AND LINEAR LOADING RATES (METRIC)

(SOP TABLE 8.1.1.10 COPIED HERE FOR CONVENIENCE)

Soil Characteristics			Hydraulic Linear Loading Rate L/day/m									
			Slope of land									
			Infiltration Loading Rate L/day/sq. meter			0-4%			>4-9%			>9%
Texture	Structure		<30mg/L	Infiltration Distance, m			Infiltration Distance, m			Infiltration Distance, m		
	Shape	Grade		12 < 24	24 < 48	48 ≤ 60	12 < 24	24 < 48	48 ≤ 60	12 < 24	24 < 48	48 ≤ 60
COS, MS, LCOS, LMS	--	OSG	14.7	74.6	89.5	104.4	89.5	104.4	119.3	104.4	119.3	134.2
FS, VFS, LFS, LVFS	--	OSG	24.5	67.1	52.0	96.9	74.6	89.5	104.4	89.5	104.4	119.3
COSL, MSL	--	OM	29.4	52.2	59.7	67.1	61.2	68.6	76.1	89.5	104.4	119.3
		PL	1	24.5	52.2	59.7	67.1	61.2	68.6	76.1	74.6	89.5
	PR/BK/GR	1	29.4	67.1	82.0	96.9	74.6	89.5	104.4	89.5	104.4	119.3
		2,3	29.4	67.1	82.0	89.5	74.6	89.5	104.4	89.5	104.4	119.3
FSL, VFSL	--	OM	17.6	34.3	38.8	43.2	40.3	44.7	49.2	47.7	55.2	62.6
		PL	1	17.6	34.3	38.8	43.2	40.3	44.7	49.2	47.7	55.2
	PR/BK/GR	1	22	52.2	59.7	67.1	56.7	64.1	71.6	61.2	68.6	76.1
		2,3	30.8	56.7	64.1	71.6	61.2	68.6	76.1	65.6	73.1	80.5
L	--	OM	22	34.3	38.8	43.2	40.3	47.7	49.2	43.3	50.7	62.6
		PL	1	22	52.2	59.7	67.1	56.7	64.1	71.6	61.2	68.6
	PR/BK/GR	1	22	52.2	59.7	67.1	56.7	64.1	71.6	61.2	68.6	76.1
		2,3	30.8	56.7	64.1	71.6	61.2	68.6	76.1	65.6	73.1	80.5
SIL	--	OM	8.8	37.3	44.7	52.2	40.3	47.7	55.2	43.3	50.7	58.2
		PL	1	7.3	37.3	414.7	52.2	40.3	47.7	55.2	43.3	50.7
	PR/BK/GR	1	22	40.3	44.7	49.2	44.7	49.2	53.7	52.2	59.7	67.1
		2,3	30.8	47.7	55.2	62.6	52.2	59.7	67.1	56.7	64.1	71.6
SCL, CL, SICL, SI	--	OM	0.0									
		PL	1	7.3	25.4	32.8	40.3	28.3	35.8	43.2	31.3	38.8
	PR/BK/GR	1	13.2	37.3	44.7	52.2	40.3	47.7	55.2	43.3	50.7	58.2
		2,3	22	43.3	50.7	58.2	47.7	55.2	62.6	52.2	59.7	67.1
SC, C, SIC	--	OM	0.0									
		PL	1,2,3	0.0								
	PR/BK/GR	1	0.0									
		2,3	9.8	37.3	44.7	52.2	40.3	47.7	55.2	43.3	50.7	58.2
HC	--	OM	0.0									
		PL	1,2,3	0.0								
	PR/BK/GR	1	0.0									
		2,3	7.8	31.3	38.8	46.2	34.3	41.8	49.2	37.3	44.7	52.2

2.0 Design and Installation

TABLE 4: EFFLUENT SOIL LOADING RATES AND LINEAR LOADING RATES (IMP. GAL)

(SOP TABLE A.1.E.1 COPIED HERE FOR CONVENIENCE)

Soil Characteristics			Infiltration Loading Rate gal/day/ft ²	Hydraulic Linear Loading Rate (gal/d/ft)								
				Slope of land								
				0-4%			>4-9%			>9%		
Texture	Structure		<30mg/L	Infiltration Distance (in)			Infiltration Distance (in)			Infiltration Distance (in)		
	Shape	Grade		12 < 24	24 < 48	48 ≤ 60	12 < 24	24 < 48	48 ≤ 60	12 < 24	24 < 48	48 ≤ 60
COS, MS, LCOS, LMS	--	OSG	0.3	5.0	6.0	7.0	6.0	7.0	8.0	7.0	8.0	9.0
FS, VFS, LFS, LVFS	--	OSG	0.5	4.5	5.5	6.5	5.0	6.0	7.0	6.0	7.0	8.0
COSL, MSL	--	OM	0.6	3.5	4.0	4.5	4.1	4.6	5.1	6.0	7.0	8.0
	PL	1	0.5	3.5	4.0	4.5	4.1	4.6	5.1	5.0	6.0	7.0
		2,3	0.2	2.5	3.0	3.5	2.7	3.2	3.7	2.9	3.4	3.9
	PR/BK/ GR	1	0.6	4.5	5.5	6.5	5.0	6.0	7.0	6.0	7.0	8.0
2,3		0.6	4.5	5.5	6.0	5.0	6.0	7.0	6.0	7.0	8.0	
FSL, VFSL	--	OM	0.36	2.3	2.6	2.9	2.7	3.0	3.3	3.2	3.7	4.2
	PL	1	0.36	2.3	2.6	2.9	2.7	3.0	3.3	3.2	3.7	4.2
		2,3	0.15	2.5	3.0	3.5	2.7	3.2	3.7	2.9	3.4	3.9
	PR/BK/ GR	1	0.45	3.5	4.0	4.5	3.8	4.3	4.8	4.1	4.6	5.1
2,3		0.63	3.8	4.3	4.8	4.1	4.6	5.1	4.4	4.9	5.4	
L	--	OM	0.45	2.3	2.6	2.9	2.7	3.0	3.3	3.2	3.7	4.2
	PL	1	0.45	3.5	4.0	4.5	3.8	4.3	4.8	4.1	4.6	5.1
		2,3	0.15	2.5	3.0	3.5	2.7	3.2	3.7	2.9	3.4	3.9
	PR/BK/ GR	1	0.45	3.5	4.0	4.5	3.8	4.3	4.8	4.1	4.6	5.1
2,3		0.63	3.8	4.3	4.8	4.1	4.6	5.1	4.4	4.9	5.4	
SIL	--	OM	0.18	2.5	3.0	3.5	2.7	3.2	3.7	2.9	3.4	3.9
	PL	1	0.15	2.5	3.0	3.5	2.7	3.2	3.7	2.9	3.4	3.9
		2,3	0.0	-	-	-	-	-	-	-	-	-
	PR/BK/ GR	1	0.45	2.7	3.0	3.3	3.0	3.3	3.6	3.5	4.0	4.5
2,3		0.63	3.2	3.7	4.2	3.5	4.0	4.5	3.8	4.3	4.8	
SCL, CL, SICL, SI	--	OM	0.0	-	-	-	-	-	-	-	-	-
	PL	1	0.15	1.7	2.2	2.7	1.9	2.4	2.9	2.1	2.6	3.1
		2,3	0.0	-	-	-	-	-	-	-	-	-
	PR/BK/ GR	1	0.27	2.5	3.0	3.5	2.7	3.2	3.7	2.9	3.4	3.9
2,3		0.45	2.9	3.4	3.9	3.2	3.7	4.2	3.5	4.0	4.5	
SC, C, SIC	--	OM	0.0	-	-	-	-	-	-	-	-	-
	PL	1,2,3	0.0	-	-	-	-	-	-	-	-	-
		PR/BK/ GR	1	0.0	-	-	-	-	-	-	-	-
	2,3	0.2	2.5	3.0	3.5	2.7	3.2	3.7	2.9	3.4	3.9	
HC	--	OM	0.0	-	-	-	-	-	-	-	-	-
	PL	1,2,3	0.0	-	-	-	-	-	-	-	-	-
		PR/BK/ GR	1	0.0	-	-	-	-	-	-	-	-
	2,3		0.16	2.1	2.6	3.1	2.3	2.8	3.3	2.5	3.0	3.5

3.0 Field Sizing

Example 1:

House size: Standard 3 Bedroom
 Disposal Area Sizing: FSL, BK, 3
 Slope: 0%
 Infiltrative Depth (Point of Application to Restrictive Layer): 47 inches

Lookup Peak Daily Flow and Minimum Number of Eljen GSF Modules from Table 2.

Bedrooms					
1	2	3	4	5	6
Minimum Peak Daily Wastewater Flow Liters/Day (imp. Gal/day)					
680 (150)	1360 (300)	1530 (337.5)	2040 (450)	2550 (562.5)	3060 (675)
Recommended Minimum Number of Modules					
10	14	18	24	30	36

Peak Design Flow: 337.5 IG/d

Minimum Number of A42 Modules: 18

Lookup Hydraulic Loading Rate and Hydraulic Linear Loading Rate from Table 3 or 4:

Soil Characteristics			Hydraulic Linear Loading Rate (gal/d/ft)									
			Slope of land									
			0-4%			>4-9%			>9%			
Texture	Structure		Infiltration Loading Rate gal/day/ft ² <30mg/L	Infiltration Distance (in)			Infiltration Distance (in)			Infiltration Distance (in)		
	Shape	Grade		12 < 24	24 < 48	48 ≤ 60	12 < 24	24 < 48	48 ≤ 60	12 < 24	24 < 48	48 ≤ 60
FSL, VFSL	--	OM	0.36	2.3	2.6	2.9	2.7	3.0	3.3	3.2	3.7	4.2
	PL	1	0.36	2.3	2.6	2.9	2.7	3.0	3.3	3.2	3.7	4.2
		2, 3	0.15	2.5	3.0	3.5	2.7	3.2	3.7	2.9	3.4	3.9
	PR/BK/ GR	1	0.45	3.5	4.0	4.5	3.8	4.3	4.8	4.1	4.6	5.1
		2,3	0.63	3.8	4.3	4.8	4.1	4.6	5.1	4.4	4.9	5.4

Infiltration Loading Rate: 0.63 gpd / ft²

Hydraulic Linear Loading Rate: 4.8 gpd / ft

PRIMARY SOLUTION – MINIMIZE CONTOUR LENGTH

Calculate Minimum Absorption Area:

Peak Daily Flow ÷ HLR = 337.5 gpd ÷ 0.63 gpd / ft² = 535.7 ft², Round up to 536 ft²

Calculate Minimum Contour Length:

Peak Daily Flow ÷ HLLR = 337.5 gpd ÷ 4.3 gpd / ft = 78.5 ft, Round up to 79 ft

Calculate Minimum Coverage Required per Module:

Area ÷ Modules = 536 ft² ÷ 18 = 29.8 ft² per Module

Note: 29.8 ft² is less than the maximum coverage of 35 ft² per modules, so no need for additional modules for coverage.

3.0 Field Sizing

Calculate Minimum Width for Minimum Contour Length:

$$\text{Area} \div \text{Length} = 536 \text{ ft}^2 \div 79 \text{ ft} = 6.8 \text{ ft}$$

Note: The maximum width per row is 5 ft. At 5 ft the modules will also need to be spaced along the pipe to achieve each module's minimum required footprint. Reference Figure 4.

Calculate Required Contour Length to Achieve Infiltration Area at 5 ft width:

$$\text{Absorption Area} \div 5 \text{ ft} = 536 \text{ ft}^2 \div 5 \text{ ft} = 107.2 \text{ ft, round to 108 ft.}$$

Determine if more modules are required to satisfy the HLLR requirement.

$$\text{Required Contour Length} \div \text{Modules} = 108 \text{ ft} \div 18 = 6 \text{ ft per module.}$$

6 ft is within the length range of an individual module, so no need to add modules, simply space modules in the 108 ft field to achieve treatment and dispersal.

Note: The length of a module is 4 ft, so each module will require 1 foot of sand before and after. This will space the modules 2 feet apart in the field, and 1 foot away from the beginning and end of the field.

Final Dimension Layout

(Note: System layout and number of rows will vary based on site constraints)

Contour Length	108 ft
Infiltrative Area Total Width	5 ft.
Minimum Number of Modules	18 (1 row of 18)
Footprint per Module	30 ft ² ((5'-0" x 6'-0")
System Area	540 ft ²

FIGURE 5: PLAN VIEW – EXAMPLE 1

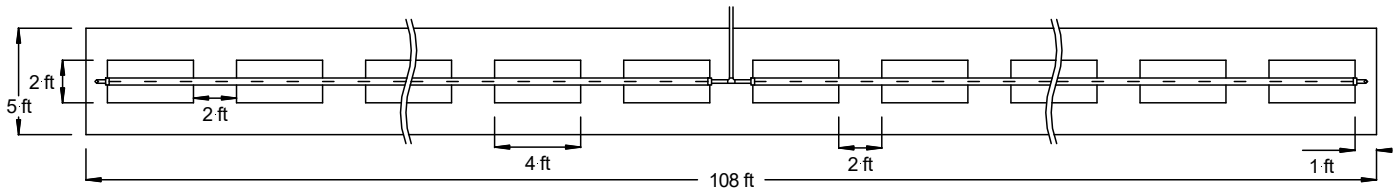
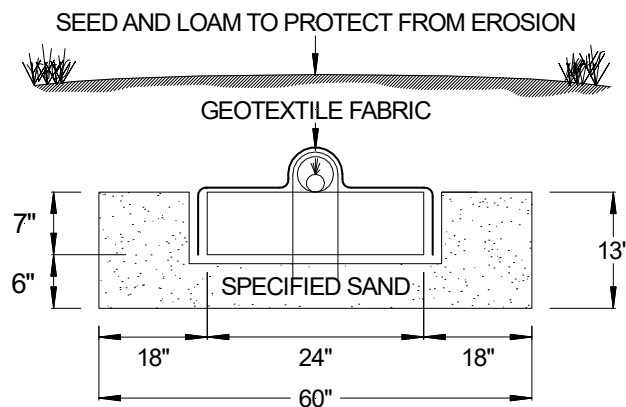

FIGURE 6: SECTION VIEW – EXAMPLE 1



3.0 Field Sizing

Example #2

House size: Standard 3 Bedroom
 Design Flow: 337.5 gpd
 Soil Type: L, OM
 Slope: 12%
 Infiltration Depth (Point of Application to Restrictive Layer): 36"

Lookup Peak Daily Flow and Minimum Number of Eljen GSF Modules from Table 2.

Bedrooms					
1	2	3	4	5	6
Minimum Peak Daily Wastewater Flow Liters/Day (imp. Gal/day)					
680 (150)	1360 (300)	1530 (337.5)	2040 (450)	2550 (562.5)	3060 (675)
Recommended Minimum Number of Modules					
10	14	18	24	30	36

Peak Design Flow: 337.5 IG/d

Minimum Number of A42 Modules: 18

Lookup Hydraulic Loading Rate and Hydraulic Linear Loading Rate from Table 3 or 4:

Soil Characteristics			Infiltration Loading Rate gal/day/ft ²	0-4%			>4-9%			>9%		
Texture	Structure			Infiltration Distance (in)			Infiltration Distance (in)			Infiltration Distance (in)		
	Shape	Grade	<30mg/L	12 < 24	24 < 48	48 ≤ 60	12 < 24	24 < 48	48 ≤ 60	12 < 24	24 < 48	48 ≤ 60
L	--	OM	0.45	2.3	2.6	2.9	2.7	3.0	3.3	3.2	3.7	4.2
		1	0.45	3.5	4.0	4.5	3.8	4.3	4.8	4.1	4.6	5.1
	PL	2,3	0.15	2.5	3.0	3.5	2.7	3.2	3.7	2.9	3.4	3.9
		1	0.45	3.5	4.0	4.5	3.8	4.3	4.8	4.1	4.6	5.1
	PR/BK/ GR	1	0.45	3.5	4.0	4.5	3.8	4.3	4.8	4.1	4.6	5.1
		2,3	0.63	3.8	4.3	4.8	4.1	4.6	5.1	4.4	4.9	5.4

Hydraulic Loading Rate: 0.45 IG/d / ft²

Hydraulic Linear Loading Rate: 3.7 IG/d / ft

PRIMARY SOLUTION – MINIMIZE CONTOUR LENGTH

Calculate Minimum Absorption Area

$$\text{Peak Daily Flow} \div \text{HLR} = 337.5 \text{ gpd} \div 0.45 \text{ gpd} / \text{ft}^2 = 750 \text{ ft}^2$$

Calculate Minimum Contour Length

$$\text{Peak Daily Flow} \div \text{Linear Loading Rate} = 337.5 \text{ gpd} \div 3.7 \text{ gpd} / \text{ft} = 91.2 \text{ ft. (91' 3")}$$

Calculate Minimum Width for Minimum Contour Length:

$$\text{Area} \div \text{Length} = 750 \text{ ft}^2 \div 91.2 \text{ ft} = 8.2 \text{ ft}$$

Note: Two rows are required to cover 8.2 ft width.

3.0 Field Sizing

Calculate Minimum Coverage Required per Module:

$$\text{Area} \div \text{Modules} = 750 \text{ ft}^2 \div 18 = 41.7 \text{ ft}^2 \text{ per Module}$$

Note: 41.7 ft² is greater than the maximum coverage of 35 ft² per modules, so additional modules are required for coverage.

Calculate Total Modules Required for Coverage by Module Area:

$$\text{Area} \div 35 \text{ ft}^2 \text{ (max area per module)} = 750 \text{ ft}^2 \div 35 \text{ ft}^2 = 21.4 \text{ modules, Round up to 22 modules.}$$

Note: 22 is greater than the minimum 18 required for treatment and is greater than the minimum of 6 per bedroom.

Calculate Total Modules Required for Coverage by Contour Length:

$$\text{Contour Length} \div \text{Maximum Module Length} = 91.2 \text{ ft} \div 7 \text{ ft} = 13 \text{ modules per row.}$$

$$2 \text{ Rows X } 13 \text{ modules per row} = 26 \text{ Modules.}$$

Note: 26 is greater than the minimum 18 required for treatment, is greater than the minimum of 6 per bedroom and is greater than the coverage calculation.

Minimum Number of Modules Required is: 26

Final Dimension Layout

(Note: System layout and number of rows will vary based on site constraints)

Contour Length	91' 3"
Infiltrative Area Total Width	8' 3"
Minimum Number of Modules	26 (2 rows of 13)
Footprint per Module	29 ft ² (4'-1 1/2" x 7'-0")
System Area	753 ft ²

FIGURE 7: PLAN VIEW – EXAMPLE 2 – OPTION 1 TRENCHES

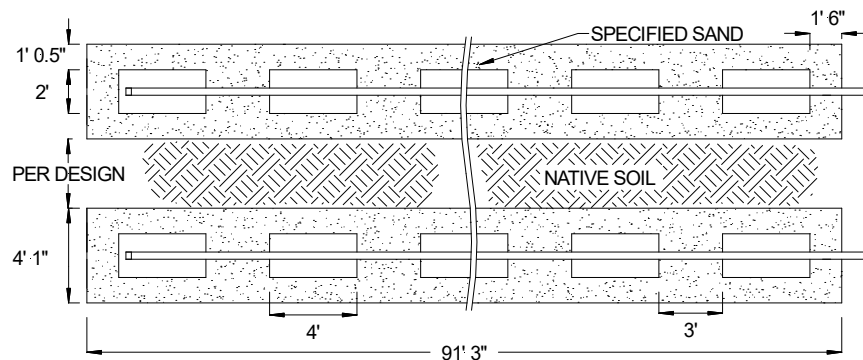

3.0 Field Sizing

FIGURE 8: PLAN VIEW – EXAMPLE 2 - BED

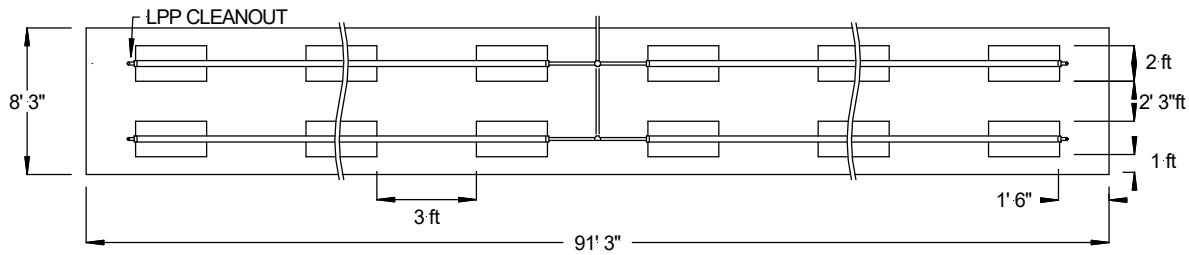

ALTERNATIVE SOLUTION – SINGLE ROW

Calculate Contour Length Required at Maximum Width per Single Row:

$$\text{Area} \div \text{Length} = 750 \text{ ft}^2 \div 5 \text{ ft} = 150 \text{ ft}$$

Calculate Required Specified Sand Length per module to meet contour length:

$$150 \text{ ft} \div 18 \text{ modules} = 8.3 \text{ ft}$$

Note: 9.3 ft is more than the maximum length of 7 ft per modules, so additional modules are required to meet contour length.

Calculate Number of Modules Required to Cover Contour Length:

$$150 \text{ ft} \div 7 \text{ ft} = 21.4 \text{ modules, round up to 22 modules}$$

Note: 22 modules is greater than the 18 modules required for treatment, so this solution uses the least number of modules.

Final Dimension Layout – Alternate Solution

(Note: System layout and number of rows will vary based on site constraints)

Contour Length	150 ft
Infiltrative Area Total Width	5 ft
Number of Modules	22 (1 row of 22)
Footprint per Module	34 ft ² (5'-0" x 6'-10")
System Area	750 ft ²

FIGURE 9: PLAN VIEW – EXAMPLE 2 - ALTERNATIVE SOLUTION

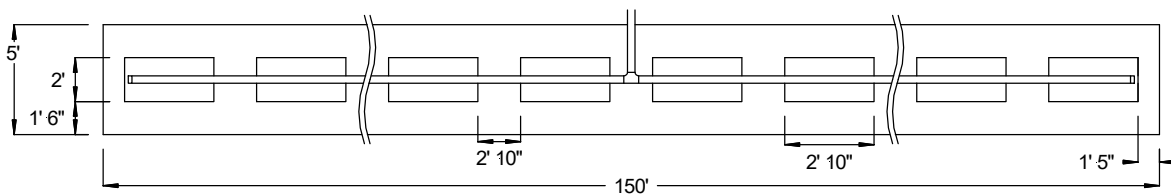

4.0 Additional Figures

FIGURE 10: SECTION VIEW – TRENCH SYSTEM – MULTIPLE LATERALS

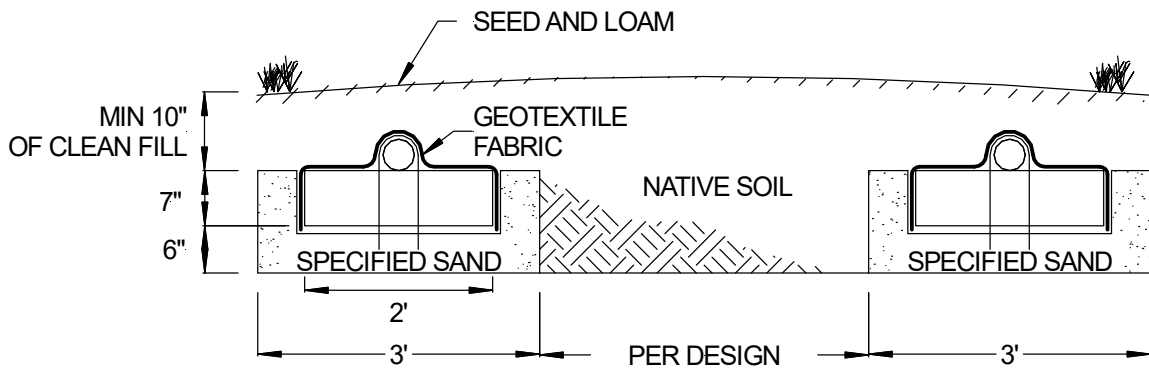

FIGURE 11: SECTION VIEW – TRENCH SYSTEM – SLOPING SITE

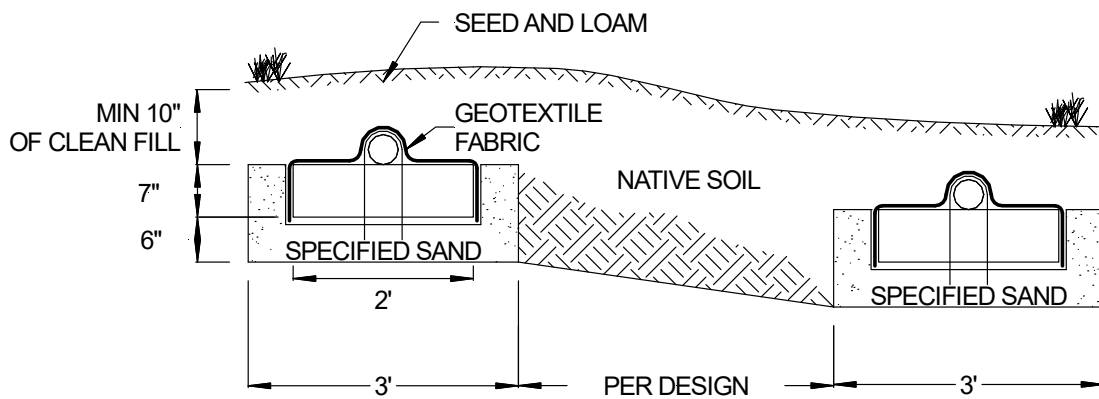
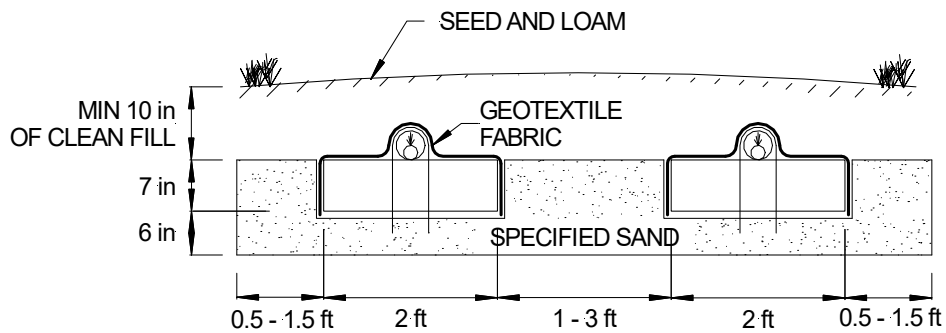
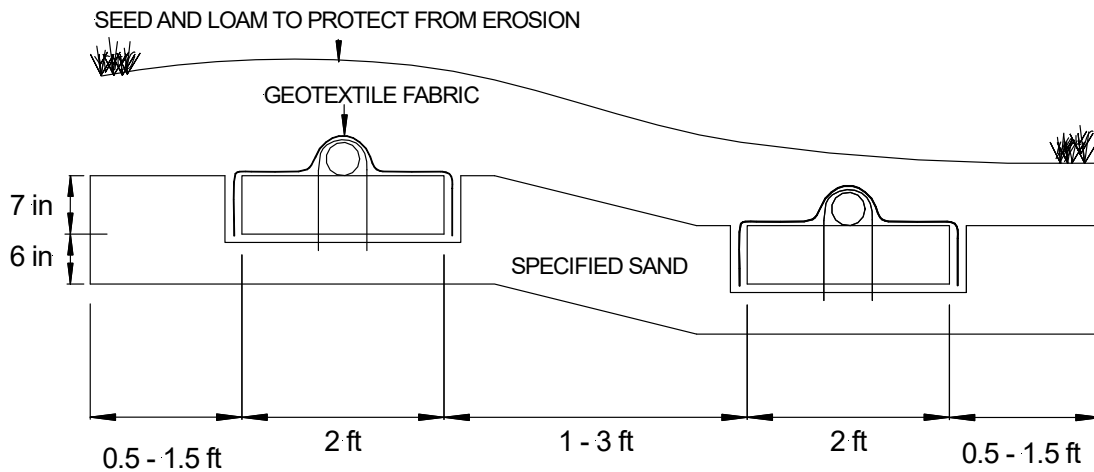

FIGURE 12: SECTION VIEW – BED SYSTEM EXAMPLE



4.0 Additional Figures

FIGURE 13: SECTION VIEW – 2 LATERAL BED SYSTEM; SLOPING SITE



Note: If the drop is over 15 cm (6 in), use two times the elevation drop as minimum spacing between module rows. Rows can be separated by up to 90 cm (3 ft) to increase effective infiltrative area (widthwise).

FIGURE 14: RAISED BED (SAND MOUND) CROSS SECTION

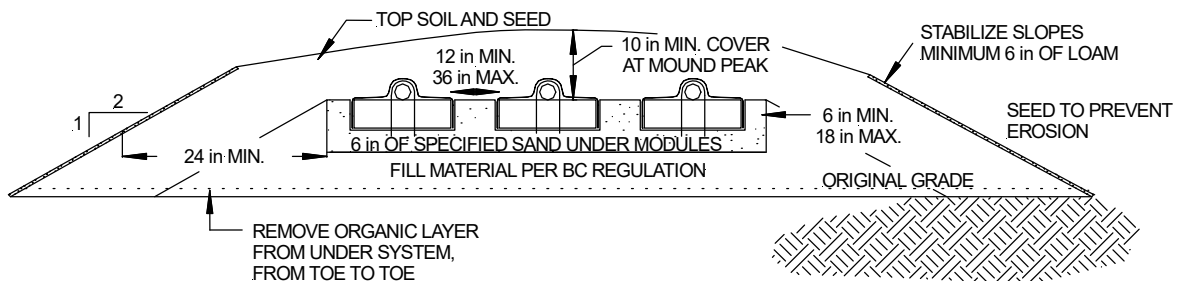
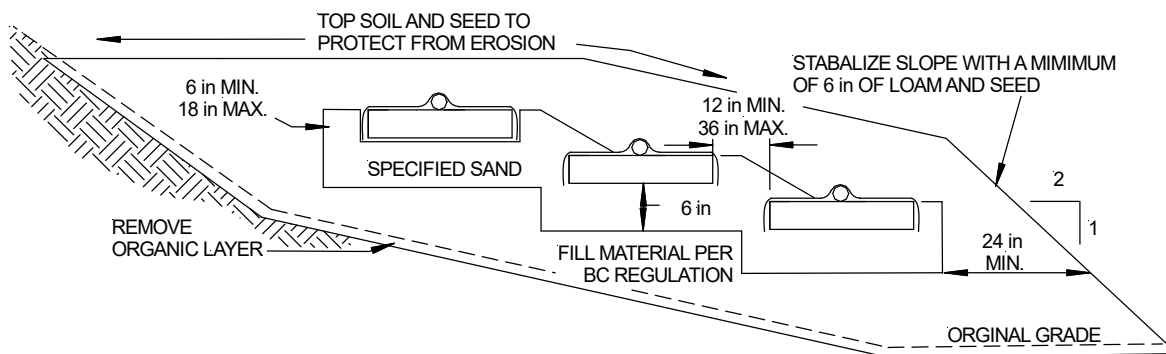

FIGURE 15: RAISED BED ON SLOPE



Note: If the drop is over 15 cm (6 in), use two times the elevation drop as minimum spacing between module rows. Rows can be separated by up to 90 cm (3 ft) to increase effective infiltrative area (widthwise).

5.0 Installation Guidelines

1. Ensure all components leading to the GSF system are installed properly. Septic tank effluent filters are strongly encouraged with the GSF system.
2. Determine the number of GSF Modules required using the sizing formula.
3. Prepare the site. Do not install a system on saturated ground or wet soils that are smeared during preparation. Keep machinery off infiltrative areas.
4. Plan all drainage requirements up-slope of the system. Set soil grades to ensure that storm water drainage and ground water is diverted away from the absorption area once the system is complete.
5. Remove the organic soil layer. Prepare the receiving layer to maximize the interface between the native soil and Specified Sand. Minimize walking in the absorption area prior to placement of the Specified Sand to avoid soil compaction.
6. Place fill material meeting SOP 2021 requirements onto the soil interface as you move down the excavated area. If this is done in two steps, bring in the fill material from the up-slope side of the excavation. Place specified sand in a 15 cm (6 in) lift and stabilize by foot, a handheld tamping tool or a portable vibrating compactor. The minimum stabilized height below the GSF module must be level at 15 cm (6 in).
7. Place GSF modules with **PAINTED STRIPE FACING UP**, end to end on top of the specified sand along their 120 cm (4 ft) length.
8. A standard perforated distribution pipe is centered along the module's length. Orifices are set at the 4 & 8 o'clock position.
9. All distribution pipes are secured with manufacturers supplied wire clamps, one per module.
10. Insert a PVC Sch. 40 pressure pipe (size per design and code) into the standard perforated distribution pipe. The pressure pipe orifices are set at the 12 o'clock position as shown in Figure 12. Each pressure lateral will have a drain hole at the 6 o'clock position. Each pressure lateral shall include sweeping cleanouts at the terminal ends and be accessible from grade.
11. **Cover fabric substitution is not allowed.** The installer should lay the Eljen provided geotextile cover fabric lengthwise down the row, with the fabric fitted to the perforated pipe on top of the GSF modules. Fabric should be neither too loose, nor too tight. The correct tension of the cover fabric is set by:
 - a. Spreading the cover fabric over the top of the module and down both sides of the module with the cover fabric draped over the top of the perforated distribution pipe.
 - b. Place shovelfuls of Specified Sand directly over the pipe allowing the cover fabric to form a mostly vertical orientation along the sides of the pipe. Repeat this step moving down the pipe.In applications where modules are spaced end-to-end to increase effective basal area and contour length, each module is to have fabric wrapped at each end and *all perforated holes not discharging at least 15 cm (6 in) onto a GSF module must be sealed.* See Figure 4 for an example.
12. Ensure there is a minimum of 15 cm (6 in) of specified sand surrounding the GSF modules. Slope the sand away from the system as described on the plan.
13. Complete backfill with a minimum of 25 cm (10 in) of cover material measured from the top of the module. Use well graded native soil fill that is clean, porous and devoid of large rocks. Do not use wheeled equipment over the system. A light track machine may be used with caution, avoiding crushing or shifting of pipe assembly.
14. Divert surface runoff from the system. Finish grade to prevent surface ponding. Topsoil and seed system area to protect from erosion.

Note: An installation video is available for viewing at www.eljen.com

6.0 Dosing Distribution Guidance

6.1 DOSING DESIGN AND FLOW RATE: Set the floats or pump time controls to deliver a maximum of 10 liters (2.2 IG) per A42 module for each dosing cycle. Additional volume for the effluent draining back to the dose tank must be added to this volume.

$$\text{Dose Volume} = \text{number of modules} \times 10 \text{ L (2.2 IG) per module} + \text{force main volume}$$

For example, if the system uses 24 modules, set the dose volume at 240 liters (52.9 IG) plus the volume of effluent in the force main. A 50 mm (2 in) pipe stores 1.963 liters per meter (0.1318 IG/ft). Using 2 m (6.5 ft) of 50 mm (2 in) pipe, the pipe storage volume is 3.93 liters (0.87 IG). This is added to the 240-liter (52.9 IG) dose volume for a sum total of 244 liters (53.7 IG) per dosing cycle.

7.0 Pressure Distribution Guidance

7.1 PRESSURE DISTRIBUTION: Dosing with small diameter pressurized laterals is acceptable for GSF systems. The pipe networks must be engineered and follow principles established for pressure distribution. Using pipe-in-pipe networks as shown in Figure 12, it is recommended that there is a minimum of one orifice per module. Flushing ports are required to maintain the free flow of effluent from orifices at the distal ends of each lateral. Contact Eljen's Technical Resource Department at 1-800-444-1359 for more information on pressure distribution systems.

Standard procedures for design of pressure distribution networks apply to the GSF filter. A minimum orifice size according to the regulations shall be maintained. A drain hole is required at the 6 o'clock position of each pressure lateral for drainage purposes. The lateral pipe network, constructed of PVC Sch. 40 pipe (*size per design and code*), is placed within a standard 10 cm (4 in) perforated pipe. The perforation in the 10 cm (4 in) outer pipe are set at the 4 and 8 o'clock position, the drilled orifices on the pressure pipe are set to spray at the 12 o'clock position directly to the top of the 10 cm (4 in) perforated pipe as shown below. Pressure clean outs are required at the end of each lateral.

FIGURE 16: PRESSURE PIPE PLACEMENT

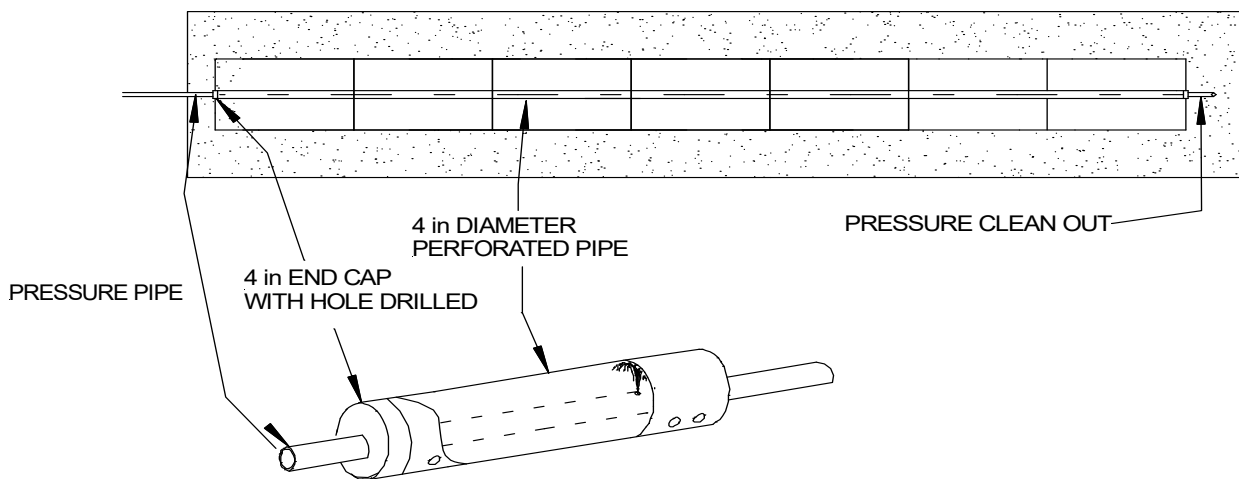

PRESSURE PIPE CROSS SECTION FOR ALL APPLICATIONS

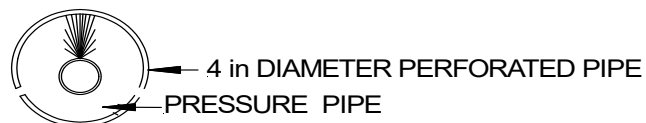

FIGURE 17: PRESSURE CLEAN OUT

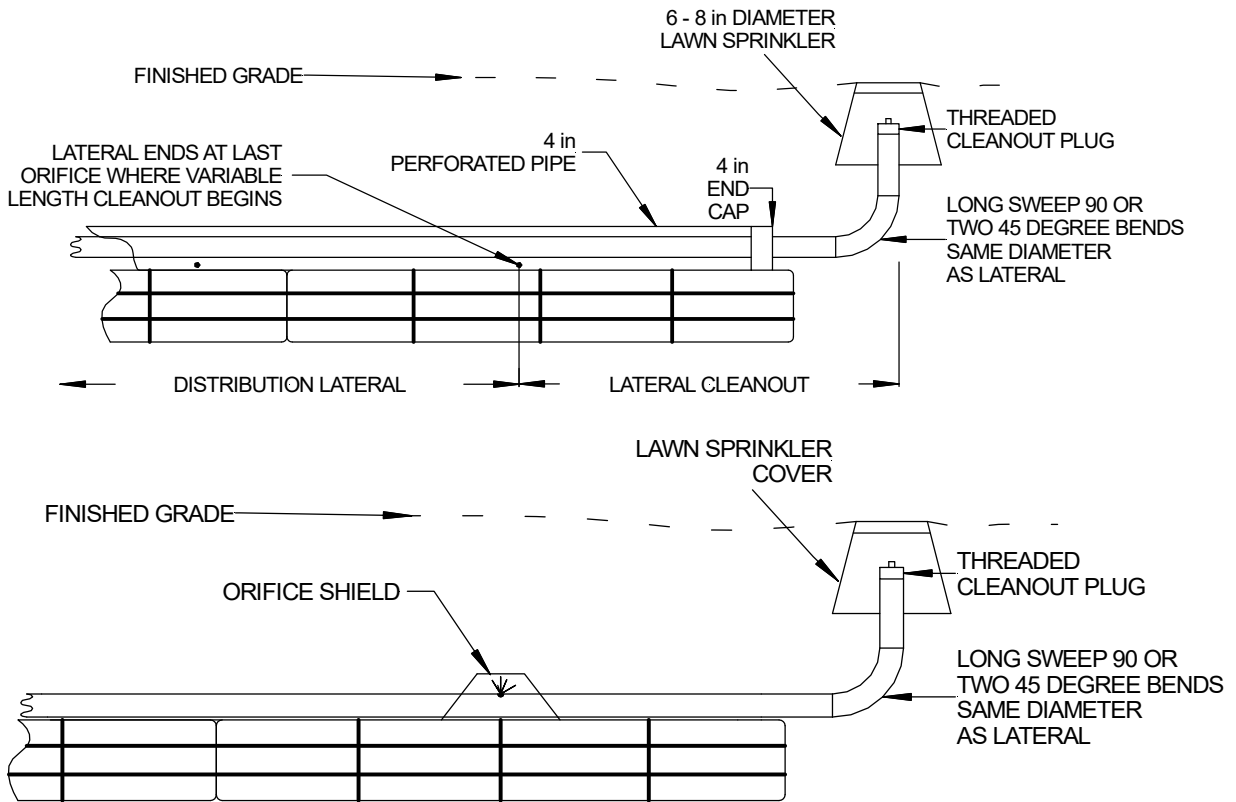
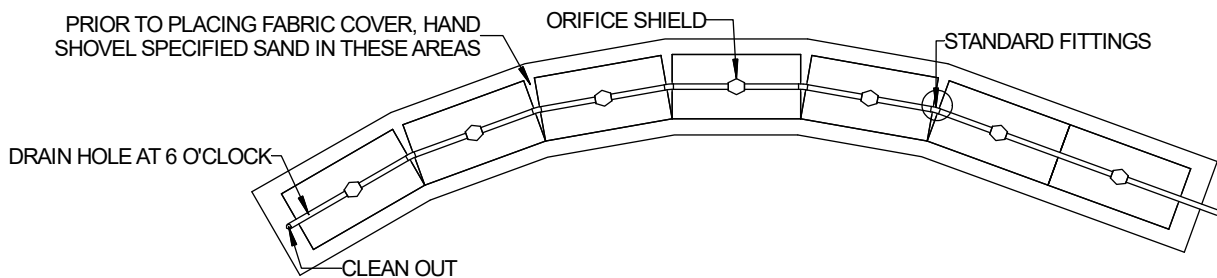

FIGURE 18: CONTOURED TRENCH PRESSURE DISTRIBUTION USING ORIFICE SHIELDS



GSF Pressure Distribution trench placed on a contour or winding trenches to maintain horizontal separation distances.

8.0 System Ventilation

8.1 SYSTEM VENTILATION: Air vents are only required in dispersal field systems when located under impervious surfaces or systems with more than 45 cm (18 in) of cover material as measured from the top of the GSF module to finished grade. This will ensure proper aeration of the modules and sand filter. The GSF has aeration channels connecting to cuspatations within the GSF modules. Under normal operating conditions, only a fraction of the filter is in use. The unused channels remain open for intermittent peak flows and the transfer of air. The extension of the distribution pipe to the vent provides adequate delivery of air into the GSF system, as shown in Figure 16.

Home plumbing operates under negative pressure due to hot water heating the pipes and reducing the density of air in the house vent. As hot air rises and exits the home, it must be replaced by air from the GSF. To maintain this airflow and fully aerate the GSF system, it is important that air vents are located only on the distal end of the GSF pipe network. If the system is specified with greater than 45 cm (18 in) of cover or has impervious cover, an additional 10 cm (4 in) diameter vent line may be extended from the field piping back to the septic tank or the riser on the pump tank as shown in Figure 15. This maintains the continuity of airflow from the field into the house plumbing.

For the GSF system, the vent is a 10 cm (4 in.) diameter pipe extended to a convenient location behind shrubs, as shown in Figure 17. Corrugated pipe can be used with the placement and grade such that any condensation that may accumulate in the pipe does not fill and thus close off this line. If the vent is extended, the pipe must not drain effluent and must have an invert higher than the system. Elevated systems requiring venting must elevate the first meter of vent line above the top of the GSF with fittings to prevent effluent from migrating down the vent. The vent can then be pitched away from the system to a discrete area. A drain hole must be installed at the lowest point to drain any condensation.

8.2 AIR BY-PASS LINE: Air by-pass lines are required for pressurized systems with greater than 45 cm (18 in) of cover of the modules. This promotes the movement of air from the vents back to the high vent in the home or business. This is accomplished by connecting an air by-pass line to a footer on the system that has a vent and plumbing it back into the pump chamber or septic system.

FIGURE 19: AIR BY-PASS LINE DETAIL FOR VENTING OF PUMPED SYSTEMS (WHEN REQUIRED)

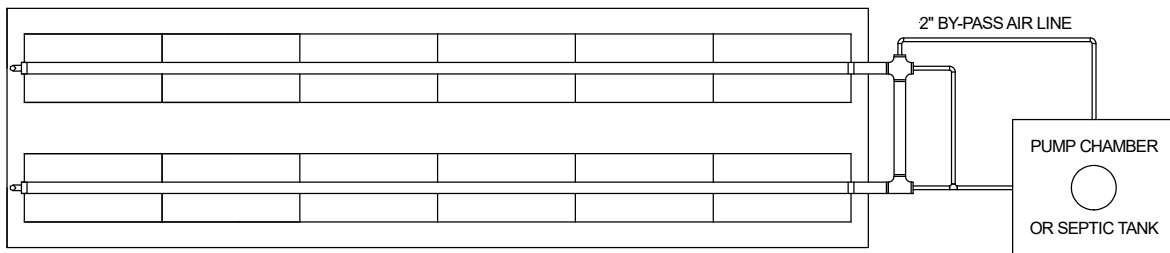

8.0 System Ventilation

8.3 VENT PIPE FOR LOW PRESSURE SYSTEMS: Systems with over 45 cm (18 in) of cover over the top of the modules require a vent. If the system is a low-pressure distribution system, ensure that the LPP clean outs are located in the vent for easy access.

FIGURE 20: VENT LAYOUTS FOR LOW PRESSURE SYSTEMS

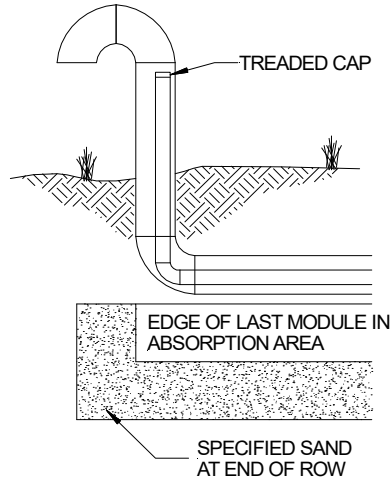

8.3 VENTILATION PLACEMENT: In a GSF system, the vent is usually a 10 cm (4 in) diameter pipe extended to a convenient location behind shrubs, as shown in the figure below. Corrugated pipe may be used. If using corrugated pipe, ensure that the pipe does not have any bends that will allow condensation to pond in the pipe. This may close off the vent line. The pipe must have an invert higher than the system so that it does not drain effluent.

FIGURE 21: GSF WITH 4" VENT EXTENDED TO CONVENIENT LOCATION

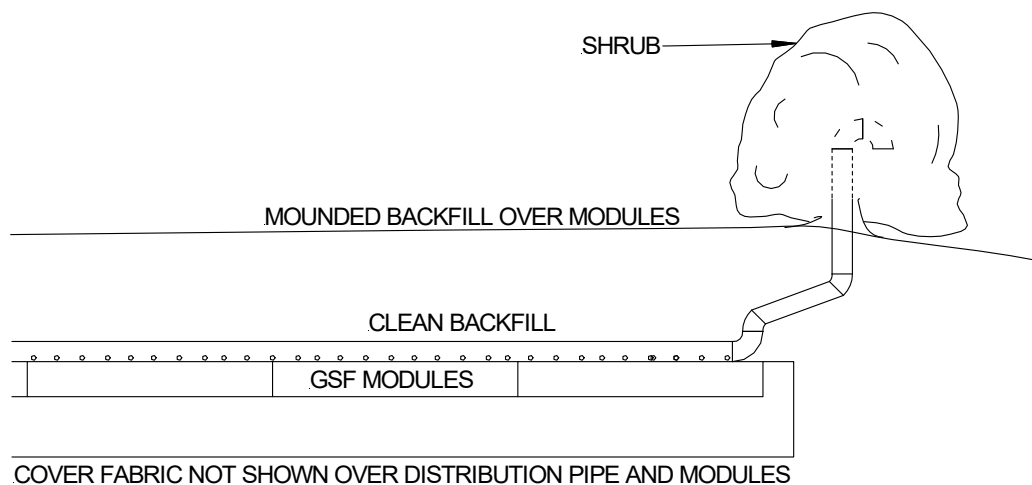

9.0 Required Notes on Design Plans

1. This system (IS/IS NOT) designed for the use of a garbage disposal.
2. This system is NOT designed for backwash from a water softener or water filter.
3. This system is NOT designed for condensate from a high-efficiency furnace.
4. This system IS design for _____ wastewater only.
5. Organic Loam Layer must be removed from in-situ soil infiltrative area and slope extension areas prior to fill placement. Scarify subsoil prior to fill placement.
6. All fill material shall meet SOP 2021 requirements. The 15 cm (6 in) of Specified System Sand underneath and surrounding the GSF modules shall be concrete sand meeting the requirements of ASTM C33 with less than 10% passing a #100 sieve and less than 5% passing a #200 sieve.
7. Backfill material can be suitable soil with no stones larger than 5 cm (2 in) in any dimension to a minimum depth of 25 cm (10 in) over the top of the distribution pipe.
8. Any system that is more than 45 cm (18 in) below finish grade as measured from the top of the module shall be vented.
9. This design complies with and must be installed in accordance with the February 2024 Eljen GSF Design and Installation Manual for Alberta.
With the following exceptions: (List any exceptions here)

10.0 Commercial Recommendations and Guidance

Commercial systems differ from residential systems relative to wastewater characteristics, effluent distribution strategies, peak flows, system size and geometry. As these systems are normally larger, the designer must also consider the collection systems and their integrity, groundwater hydrology, drainage above and below the GSF system and design accordingly.

Designers should carefully review and document with their client effluent BOD₅ and TSS concentrations and water use numbers. The designer should document that the system installation meets the technology supplier's specifications to ensure long-term performance. In addition, designers must be attentive to special details of the system, conduct follow-through startup and document technical capabilities for personnel required for Operation and Maintenance of the system.

To determine design flow for commercial systems, with the exception that the highest measured single day flow in a 12-month period shall not result in a design flow less than the measured average flow with a peaking factor of 2 to 3 depending on the type of usage.

Dispersion of effluent across a bed system or down a row of modules in a serially loaded system must be specifically addressed in the design plans. A variety of wastewater delivery options exists and includes pressure distribution, pressure dosing, and gravity dispersed type systems. Wastewater volume and strength, systems size, and site conditions often dictate which type of system is designed. Designers should confer with the local permitting authority as many jurisdictions mandate pressure distribution or pressure dosing when daily wastewater flow exceeds certain levels.

Designers must also consider how the distribution of the effluent onto the GSF modules may affect the linear loading rates and allow for the means to adjust the linear loading should the soils fail to move the effluent as predicted. Longer systems are naturally preferred as this geometry reduces the linear loading and the risk of hydraulic overload with surfacing of treated effluent down slope in serial type systems.

Extremely large systems should be designed as several smaller systems allowing for independent management of the wastewater treatment system. Designs typically include valves to rotate zones into service with access to flow diversion boxes. Management plans are frequently implemented for monitoring the fluid levels and adjusting the effluent application onto the geotextile filter modules.

Larger flow groundwater recharge systems can be impacted by site drainage from above the GSF. The additional effluent can also increase the groundwater mound down slope. Recharge systems such as the GSF must be designed and located so that they can accept precipitation and the specified wastewater volume. Control and diversion of up-slope stormwater is normally included in the design. Understanding the stormwater flows onto and out of the system is essential to successful management of these systems.

Landscape position and slope impact the drainage because the gradient frequently changes with the slope of the land, especially if placed above a restrictive layer. The depth and permeability of each soil layer above the restrictive horizon impacts the groundwater mound. For example, upper horizons may be fairly permeable and accept precipitation easily. If these layers are above a more restrictive horizon, a perched water table will develop whenever it rains. Movement of this perched groundwater can influence the disposal system and if not recognized will result in surfacing effluent. Interception and diversion of the groundwater is therefore necessary with larger systems especially over restrictive soils to insure acceptance of the treated effluent under wet conditions.

Down slope hydraulic capacity is also an important consideration with larger systems. For example, a system may be located on a free draining slope, but down slope conditions show a perched water table due to a reduced hydraulic gradient. Design limits and linear loading must be considered, and these limits should be based on the limitations of these down slope soils and gradient. Ideally systems are located with diverging topography that reduces the linear loading and results in the effluent moving down slope.

10.0 Commercial Recommendations and Guidance

System owners should educate occupants in the operation and maintenance of the system to help ensure long term system performance. The state or local permitting authority should provide for site specific items and require inspection and evaluation of an overall operating plan as commercial systems can produce flows in the thousands of gallons per day range. Designers should also provide oversight of system installation and associated system equipment.

BWD Engineering Inc. (604-789-2204), Eljen Corporation's Western Canada Technical Representative, is available for a no cost review of any commercial GSF plan prior to submission for approval from the local approving authority. Overall responsibility for system design remains with the licensed designer and/or professional.

COMPANY HISTORY

Established in 1970, Eljen Corporation created the world's first prefabricated drainage system for foundation drainage and erosion control applications. In the mid-1980s, we introduced our Geotextile Sand Filter products for the passive advanced treatment of onsite wastewater in both residential and commercial applications. Today, Eljen is a global leader in providing innovative products and solutions for protecting our environment and public health.

COMPANY PHILOSOPHY

Eljen Corporation is committed to advancing the onsite industry through continuous development of innovative new products, delivering high quality products and services to our customers at the best price, and building lasting partnerships with our employees, suppliers, and customers.



90 Meadow Road, Windsor, CT 06095 • Tel: 800-444-1359 • Fax: 860-610-0427

www.eljen.com

