

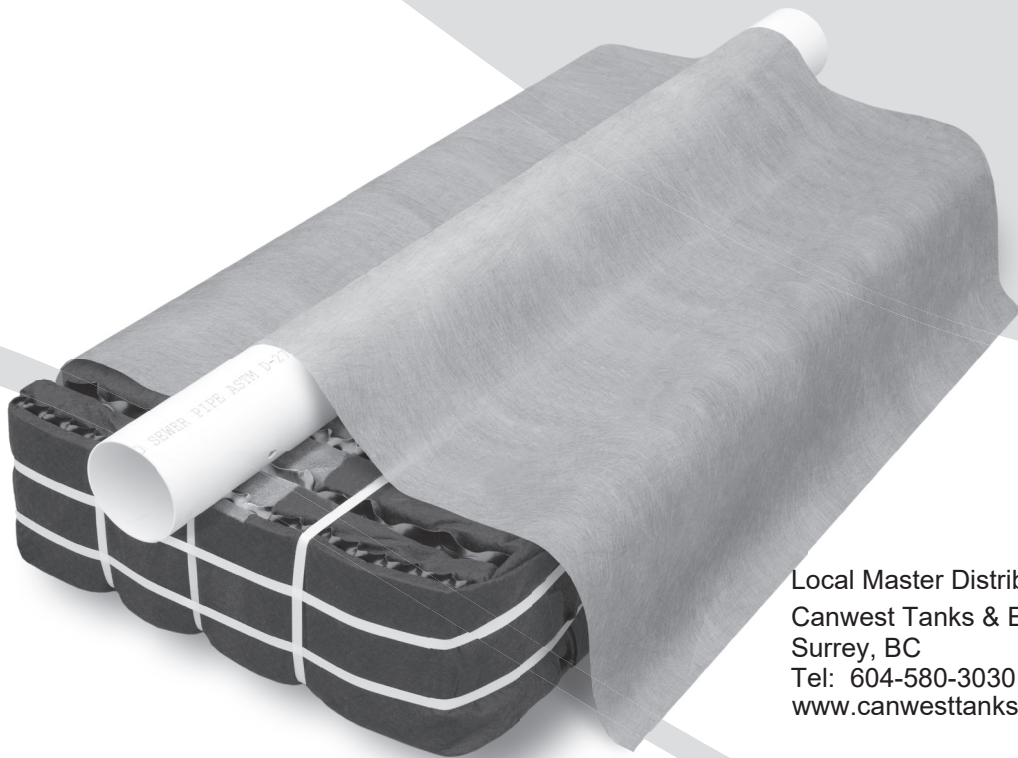

Geotextile Sand Filter

# British Columbia Design & Installation Manual



Local Master Distributor:  
Canwest Tanks & Ecological Systems  
Surrey, BC  
Tel: 604-580-3030  
[www.canwesttanks.com](http://www.canwesttanks.com)

Local Technical Representative:  
BWD Engineering Inc.  
Surrey, BC  
Tel: 604-789-2204  
[www.bwdengineering.com](http://www.bwdengineering.com)

**eljen**  
CORPORATION

*Innovative Onsite Products & Solutions Since 1970*

**March 2024**  
**[www.eljen.com](http://www.eljen.com)**

# Table of Contents

---

SUBJECT	PAGE
GLOSSARY OF TERMS .....	3
GSF SYSTEM DESCRIPTION .....	5
1.0 SYSTEM PRECONDITIONS .....	6
2.0 DESIGN AND INSTALLATION .....	7
3.0 FIELD SIZING AND GUIDELINES .....	13
4.0 ADDITIONAL FIGURES .....	18
5.0 INSTALLATION GUIDELINES .....	20
6.0 DOSING DISTRIBUTION GUIDANCE .....	21
7.0 PRESSURE DISTRIBUTION GUIDANCE .....	21
8.0 SYSTEM VENTILATION .....	23
9.0 REQUIRED NOTES ON DESIGN PLANS .....	25
10.0 COMMERCIAL RECOMMENDATIONS AND GUIDANCE .....	26
GSF DRAWINGS AND TABLES	
DRAWINGS	
FIGURE 1: GSF SYSTEM OPERATION .....	5
FIGURE 2: TYPICAL A42 CROSS SECTION .....	7
FIGURE 3: VERTICAL SEPARATION DISTANCE .....	8
FIGURE 4: A42 MODULE END-TO-END SEPARATION FOR ALL APPLICATIONS .....	9
FIGURE 5: PLAN VIEW – EXAMPLE 1 .....	14
FIGURE 6: SECTION VIEW – EXAMPLE 1 .....	14
FIGURE 7: PLAN VIEW – EXAMPLE 2 – OPTION 1 TRENCHES .....	16
FIGURE 8: PLAN VIEW – EXAMPLE 2 – OPTION 2 BED .....	17
FIGURE 9: PLAN VIEW – EXAMPLE 2 - ALTERNATIVE SOLUTION .....	17
FIGURE 10: SECTION VIEW – TRENCH SYSTEM – MULTIPLE LATERALS .....	18
FIGURE 11: SECTION VIEW – TRENCH SYSTEM – SLOPING SITE .....	18
FIGURE 12: SECTION VIEW – BED SYSTEM EXAMPLE .....	18
FIGURE 13: SECTION VIEW – 2 LATERAL BED SYSTEM; SLOPING SITE .....	19
FIGURE 14: A42 RAISED BED (SAND MOUND) CROSS SECTION .....	19
FIGURE 15: RAISED BED ON SLOPE .....	19
FIGURE 16: PRESSURE PIPE PLACEMENT .....	21
FIGURE 17: PRESSURE CLEAN OUT .....	22
FIGURE 18: CONTOURED TRENCH PRESSURE DISTRIBUTION USING ORIFICE SHIELDS .....	22
FIGURE 19: AIR BY-PASS LINE DETAIL FOR VENTING OF PUMPED SYSTEMS (WHEN REQUIRED) .....	23
FIGURE 20: VENT LAYOUTS FOR LOW PRESSURE SYSTEMS .....	24
FIGURE 21: GSF WITH 4" VENT EXTENDED TO CONVENIENT LOCATION .....	24
TABLES	
TABLE 1: SPECIFIED SAND SIEVE REQUIREMENTS .....	4
TABLE 2: STANDARD GSF A42 SIZING TABLE - RESIDENTIAL APPLICATIONS .....	11
TABLE 3: MAXIMUM HLR BASED ON SOIL TYPE (L/DAY/M <sup>2</sup> ) .....	12
TABLE 4: MAXIMUM HLLR BASED ON SOIL TYPE (L/DAY/M) .....	12

## Glossary of Terms

---

<b>A42 Module</b>	120 cm x 60 cm x 18 cm; 48" x 24" x 7" (L x W x H)
<b>*Combined Treatment and Dispersal System</b>	Combined Treatment and Dispersal System (CTDS) are passive onsite wastewater systems that combine treatment and dispersal of effluent in the same footprint.
<b>Cover Fabric</b>	The geotextile cover fabric (provided by manufacturer) that is placed over the GSF modules.
<b>*Daily Design Flow</b>	(DDF) As defined in the SPM-V3, is the flow rate used for sizing a wastewater system taking into account mass loading and peak flows. The estimated peak flow per A42 unit that is used to size a GSF system using residential strength wastewater is 72 liters per day per module.
<b>Geotextile Sand Filter</b>	The Eljen Geotextile Sand Filter (GSF) Modules and the 15 cm (6 in) sand layer at the base and 15 cm (6 in) along the sides of the modules. The GSF is a Type 2 Secondary CTDS as defined in the SPM-V3. (L x W x H) – 120cm x 90cm x 33cm (48" x 36" x 13") for each module complete with specified sand.
<b>GSF Module</b>	The individual module of a GSF system. The module is comprised of a cusped plastic core and corrugated geotextile fabric. The A42 module is used in BC.
<b>Infiltrative Surface Area</b>	Is the area covered by the Eljen GSF system at the Point of Application.
<b>*Mound Sand</b>	A sand specification as detailed in the SPM-V3 along with Clean Coarse Sand and Sand Filter Coarse Sand.
<b>Point of Application</b>	The Point of Application is the interface surface(s) where the secondary treated effluent passes from the Eljen GSF System to the native (or tertiary engineered media) receiving soils. See Figure 3, also <i>Infiltrative Surface</i> as defined in the SPM-V3.
<b>Pressure Distribution</b>	Pressure Distribution is a method of achieving Uniform Distribution, both defined in the SPM-V3. The distribution method of pipe-in-pipe recommended by Eljen, is considered an Alternate Uniform Distribution System in BC. The requirements for pipe-in-pipe distribution as an alternate uniform distribution system have been met. For further information, contact BWD Engineering at 604-789-2204 or Eljen's Technical Resource Department at 1-800-444-1359.
<b>*SHWT</b>	<b>Seasonal High-Water Table</b>

### Specified Sand

The system sand specification required for GSF systems: ASTM C33 sand with less than 10% passing #100 sieve and less than 5% passing #200 sieve. Listed below is a chart outlining the sieve requirements for the Specified Sand. (Note: Mound Sand as specified in the SPM-V3 meets this requirement)

**TABLE 1: SPECIFIED SAND SIEVE REQUIREMENTS**

ASTM C33 SAND SPECIFICATION		
Sieve Size	Sieve Square Opening Size	Specification Percent Passing (Wet Sieve)
3/8 inch	9.52 mm	100
No. 4	4.76 mm	95 - 100
No. 8	2.38 mm	80 - 100
No. 16	1.19 mm	50 - 85
No. 30	590 µm	25 - 60
No. 50	297 µm	10 - 30
No. 100	149 µm	< 10
No. 200	75 µm	< 5
<i>Note: Request a sieve analysis from your material supplier to ensure that the system sand meets the specification requirements listed above.</i>		

### SPM-V3

The **Sewerage System “Standard Practice Manual” Version 3** as published by the Ministry of Health Services – BC dated September 2014. As referenced in the Sewerage System Regulation (SSR) Section 8 (3).

### SSR

**Sewerage System Regulation** – The BC Provincial Regulation which applies to the construction and maintenance of all septic systems under 22,700 L/d DDF. For more detail see actual BC Reg. 326/2004 including amendments to BC Reg.

\*SEE ALSO SPM-V3, VOLUME I, SECTION 1.1 GLOSSARY

# GSF System Description

The Eljen GSF Geotextile Sand Filter system is a cost-effective improvement over other septic treatment technologies. Comprised of a proprietary two-stage Bio-Matt™ treatment process, the geotextile modules apply a better-than-secondary treated effluent to the soil, increasing the soil's absorption rate. The result is superior treatment in a smaller soil absorption area.

In British Columbia under the Sewerage System Regulation the Eljen GSF is a Type 2 Secondary Treatment System with the added benefit of reduced fecal coliform and reduced nitrogen. In the Standard Practice Manual – Version 3, the GSF is categorized as a Combined Treatment and Dispersal System.

In British Columbia the Eljen GSF can be configured for use in systems using trickle gravity, pump to D-Box, and full uniform distribution.

## How the GSF System Works

### Primary Treatment Zone

- Perforated pipe is centered above the GSF module to distribute septic effluent over and into corrugations created by the cusped core of the geotextile module. For pressure or uniform distribution, a pressure line with orifices is placed inside the perforated sewer pipe.
- Septic effluent is filtered through the Bio-Matt fabric. The module's unique design provides increased surface area for biological treatment that greatly exceeds the module's footprint.
- Open air channels within the module support aerobic bacterial growth on the module's geotextile fabric interface, surpassing the surface area required for traditional absorption systems.
- An anti-siltation geotextile fabric covers the top and sides of the GSF module and protects the Specified Sand and soil from clogging, while maintaining effluent storage within the module.

### Secondary Treatment Zone

- Effluent drips into the Specified Sand layer and supports unsaturated flow into the native soil. This Specified Sand/soil interface maintains soil structure, thereby maximizing the available absorption interface in the native soil. The Specified Sand supports nitrification of the effluent, which reduces oxygen demand in the soil, thus minimizing soil clogging from anaerobic bacteria.
- The Specified Sand layer also protects the soil from compaction and helps maintain cracks and crevices in the soil. This preserves the soil's natural infiltration capacity, which is especially important in finer textured soils, where these large channels are critical for long-term performance.
- Native soil provides final filtration and allows for groundwater recharge.

FIGURE 1: GSF SYSTEM OPERATION

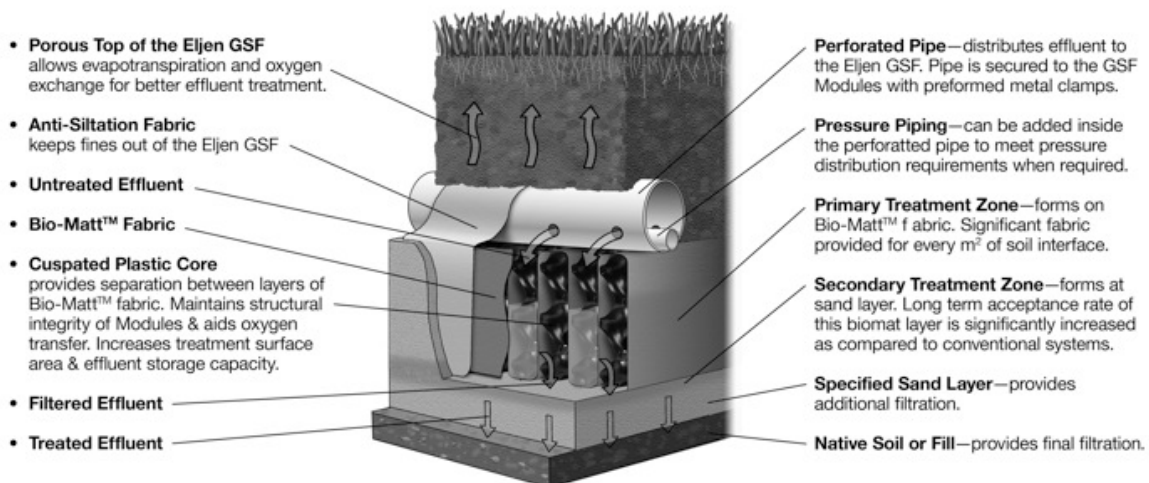

## 1.0 System Preconditions

---

**1.1 REQUIREMENTS:** GSF systems must meet the BC SPM-V3, local rules and regulations, and the steps outlined in this manual. This Manual is intended to comply completely within the BC SPM-V3. For any system outside the SPM-V3, including commercial systems, please contact BWD Engineering at 604-789-2204 or Eljen Corporation and 800-444-1359 for more information on sampling devices and techniques that can be used with the GSF system.

**1.2 WATER CONDITIONERS:** Water conditioners can adversely affect septic tank treatment and add to the hydraulic load of the effluent disposal area. **Discharged backwash from residential water conditioners shall be directed to a separate alternative disposal system.**

**1.3 GARBAGE DISPOSALS:** Garbage Disposal units (garburators) increase the organic loading to the system by 50%. If the owner wishes to use a garburator, then the Daily Design Flow must be increased by 50% which subsequently increases the size of all components of the system including the number of Eljen GSF modules and the overall field size, see SPM-V3 section II-5.1.3.2. Design Drawings and Owners Operation & Maintenance manual must include a note that clearly indicates **“Garbage Disposals ARE (or ARE NOT) allowed to be used with this system.”**

NOTE: Eljen strongly encourages the use of septic tank outlet effluent filters on all systems. Filters with higher filtration are recommended for systems with garbage disposals.

**1.4 ADDITIONAL FACTORS EFFECTING RESIDENTIAL SYSTEM SIZE:** Homes with an expected higher than normal water use should increase septic tank capacity and/or utilize multiple compartment tanks. Increasing the minimum effluent disposal area should also be considered.

Factors that may affect system size:

- Luxury homes, which may include Jacuzzi style tubs, or other high use fixtures.
- Homes with known higher than normal occupancy.
- Homes with water conditioner backwash and high efficiency furnace condensate. (Diversion from septic tank required).

Designers should use discretion when multiple additional factors are involved. Increase size in proportion to excess flow.

**1.5 SYSTEM PROHIBITED AREAS:** All vehicular traffic is prohibited over the GSF system. This is due to the compaction of material required to support traffic loading. This compaction greatly diminishes absorption below the GSF system and diminishes the void spaces that naturally exist in soils which provide oxygen transfer to the GSF system.

**1.6 CONDENSATE FROM HIGH-EFFICIENCY FURNACE:** Condensate from High-Efficiency Furnaces can adversely affect septic tank treatment and add to hydraulic load of the GSF system. **Condensate discharge from high-efficiency furnaces shall be directed to a separate alternative disposal system.**

## 2.0 Design and Installation

---

FIGURE 2: TYPICAL A42 CROSS SECTION

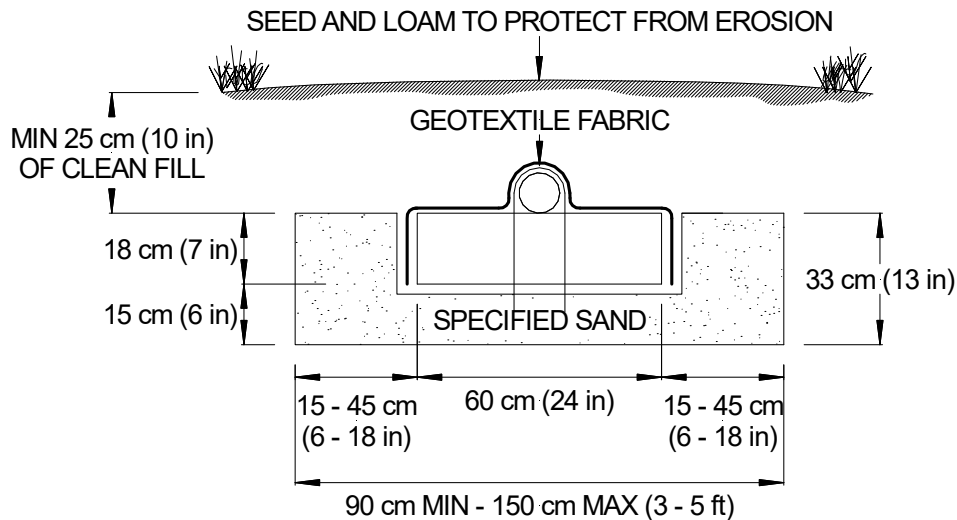

A42 MODULE (L x W x H) 120 CM x 60 CM x 18 CM (48 IN x 24 IN x 7 IN)

**All systems are required to have a minimum of:**

- 15 cm (6 in) of Specified Sand is at the edges of the GSF module.
- 15 cm (6 in) of Specified Sand is at the beginning and end of each GSF row or individual module when separated lengthwise.
- 15 cm (6 in) of Specified Sand is directly below the GSF module.
- Minimum 25 cm (10 in) of cover above the module.

**2.1 SEPTIC TANKS:** The BC SPM-V3 recommends two septic tanks in series or dual compartment tanks for all systems. Eljen supports this practice as it helps to assure long system life by reducing suspended solids and BOD to the effluent disposal area. Eljen requires the septic tank to be pumped every three years or as needed.

**2.2 SEPTIC TANK FILTERS:** Septic tank effluent filters are ***STRONGLY ENCOURAGED*** on the outlet end of septic tank. Filter manufacturers require that filters be cleaned from time to time. Ask your installer or designer for specific cleaning requirements based on the type or make of the filter installed. Eljen requires the septic tank to be pumped every three years or as needed which would be a good time to check and conduct filter maintenance.

## 2.0 Design and Installation

**2.3 VERTICAL SEPARATION TO LIMITING LAYER:** As required by the BC Sewerage System SPM- V3 or as specified by a professional. (Note in Version 3 of the SPM, an additional 15 cm of Vertical Separation has been added, in some soil categories, for Type 2 systems that reduce or remove the Type 1 bio-mat. In the case of the Eljen GSF, the bio-mat is retained allowing for the required Vertical Separation to remain the same as Type 1 designs. ROWP Planners may require a professional letter to make this departure from the SPM-V3.)

FIGURE 3: VERTICAL SEPARATION DISTANCE

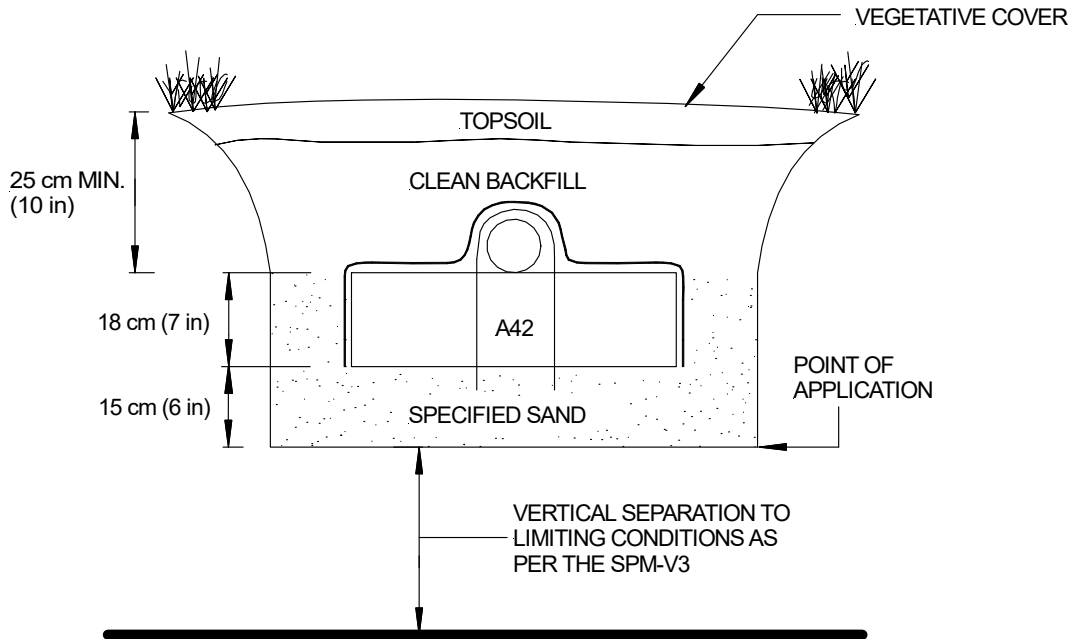

**2.4 SPECIFIED SAND SPECIFICATION FOR GSF SYSTEMS:** The first 15 cm (6 in) of Specified Sand immediately under, between rows and around the perimeter of the GSF system must be **ASTM C33 WASHED CONCRETE SAND WITH LESS THAN 10% PASSING A #100 SIEVE AND LESS THAN 5% PASSING A #200 SIEVE**. Please place a prominent note to this effect on each design drawing. See page 4 for Specified Sand requirements.

**2.5 PLACING GSF MODULES:** Each module is placed with the white paint strip up. The “painted stripe” on the GSF modules indicates the top of the module and is not intended to indicate the location of the distribution pipe. With the painted stripe facing up, all rows of GSF modules are set level, end to end on the Specified Sand layer.

Beds have a minimum spacing of 30 cm (12 in) between parallel rows. Systems with up to 15 cm (6 in) elevation drop between adjacent module rows use 30 cm (12 in) minimum spacing. If the drop is over 15 cm (6 in), use two times the elevation drop as minimum spacing between module rows. Rows can be separated by up to 90 cm (3 ft) to increase effective infiltrative area (widthwise). See Figures 8 and 12 to 16.

No mechanical connection is required between modules along the length of a row. Modules may be spaced up to 90 cm (3 ft) end-to-end along the distribution lateral to increase contour length and effective infiltrative area (lengthwise). See Figures 4, 7, 8, 9, and 12.



## 2.0 Design and Installation

FIGURE 4: A42 MODULE END-TO-END SEPARATION FOR ALL APPLICATIONS

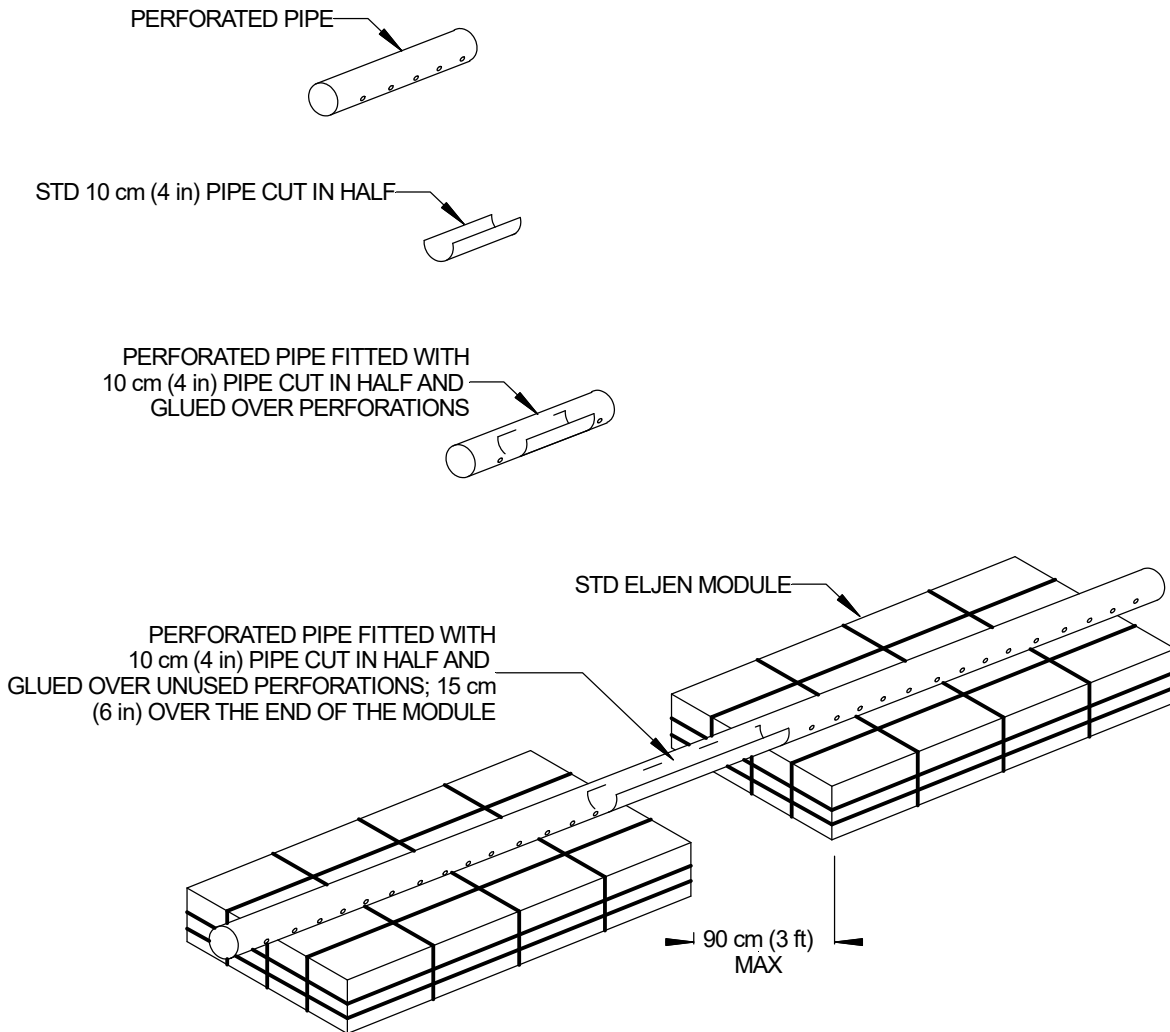

**2.6 DISTRIBUTION:** Designers may design gravity, pump to gravity, or uniform (pressure) distribution systems when using the GSF System.

For gravity and pump to gravity systems, place the approved perforated pipe on top of GSF modules with holes at four and eight o'clock. Complete system piping with solid pipe and fittings. In all cases, piping and modules must be level. Secure pipe to GSF modules with provided wire clamps, one clamp per Eljen module.

Two delivery methods are acceptable when using pressure distribution with the GSF System. Orifice shields are placed over a SCH 40 pipe, one per module. A second delivery method is also permissible. Using approved perforated pipe; a pressure manifold is placed inside the distribution pipe. Section 7 of this manual goes into details of how to construct the distribution network. All piping must meet provincial and local regulations.

In all applications, any pipe distribution holes not discharging onto the GSF module must be sealed. See Figure 4 for suggested method of sealing holes. See Figures 16 - 18 for pressure distribution illustrations.

## 2.0 Design and Installation

---

**2.7 COVER FABRIC:** Geotextile cover fabric is provided by Eljen Corporation for all GSF systems. It is placed over the top and sides of the module rows to prevent long term siltation and failure. **Cover fabric substitution is not allowed.** Fabric must be draped vertically over the pipe and must not block holes in the distribution pipe or be stretched from the top of the pipe to the outside edge of the modules. “Tenting” will cause undue stress on fabric and pipe.

*Note: If modules are spaced end-to-end, fabric must be cut and allowed to drape over and protect the ends of each spaced module. A continuous run of geotextile fabric is not allowed for these applications. Stipulate end-to-end spacing to receive adequate fabric when ordering.*

**2.8 SYSTEM VENTING:** All systems require sufficient oxygen supply to the effluent dispersal area to maintain proper long-term effluent treatment. Therefore, the following situations require venting at the far end of the system:

- Any system with more than 45 cm (18 in) of total cover as measured from the top of the module.
- Areas subject to surface compaction or sealing.

**2.9 BACKFILL & FINISH GRADING:** Carefully place backfill over the modules, followed by topsoil to complete a total minimum depth of 25 cm (10 in) as measured from the top of the distribution pipe. Systems with total cover that exceeds 45 cm (18 in) as measured from the top of the module shall be vented per Section 8. Backfill material should be a well-graded sandy loam fill; clean, porous, and devoid of rocks larger than 5 cm (2 in). Divert surface runoff from the effluent disposal area. Finish grade to prevent surface ponding. Seed loam to protect from erosion.

**2.10 BACKFILL MATERIAL FOR RAISED SYSTEMS:** Fill material below the Specified Sand for raised bed systems must be per the latest BC Regulations. Fill must be consolidated in lifts to prevent differential settling. Refer to SPM Version 3 for detailed fill specification.

**2.11 POINT OF APPLICATION:** The Point of Application is the interface surface(s) where the secondary treated effluent passes from the Eljen GSF System to the in-situ (or tertiary engineered media) receiving soils. See Figure 3.

**2.12 SYSTEM GEOMETRY:** In general, design systems long and narrow along site contours to minimize groundwater mounding especially in poorly drained low permeability soils. If possible, design level systems with equal number of modules per row.

**LEVEL SYSTEMS:** Design level in-ground or raised systems with 30 cm minimum and up to 90 cm maximum spacing between module rows, and from 0 to 90 cm spacing end to end. The system specified sand, GSF modules, and distribution pipes are installed level at their design elevations.

**SLOPED SYSTEMS:** Design level in-ground or raised systems with 30 cm minimum and up to 90 cm maximum spacing between module rows and 0-90 cm spacing end to end. Systems with up to 15 cm elevation drop between adjacent module rows use 30 cm minimum spacing. If over 15 cm drop, use two times the elevation drop as minimum spacing between module rows. The system specified sand, GSF modules, and distribution pipes are installed level at their design elevations along the site contours.

**2.13 SYSTEM SIZING:** The total basal area required is site specific and determined by the Daily Design Flow (DDF) and soils analysis as specified in the SPM-V3 or by a professional.

The GSF system is a Type 2 - Combined Treatment and Dispersal System thus requiring a reduced field size compared to a standard Type 1 stone and pipe system or chamber system.

- The number of GSF modules required (See 2.16) typically fits the required basal area and can be configured to properly cover any shape required and is the same for trench, bed or mound systems.
- In beds and mounds, a minimum of 30 cm separation is required between parallel rows of GSF modules to utilize sidewall infiltration area.
- Maximum edge-to-edge and end-to-end separation for Modules in all applications is 90 cm.

## 2.0 Design and Installation

**2.14 NUMBER OF GSF MODULES REQUIRED:** Each Eljen GSF A42 is designed to a standard loading for residential strength effluent of 72 liters per day per module for trenches and beds and mound systems.

Table 2 indicates the minimum number of GSF A42 modules required for standard homes as listed in the SPM where trench, bed and mound systems are applicable. For all systems with unlisted Peak Wastewater Flows of residential effluent the number of GSF A42 modules is calculated by dividing the selected Peak Wastewater Flow in Liters/day by 72 L/day/module.

- For trench, bed and mound sizing and configuration drawings see Sections 3 & 4 of this manual.
- For information on commercial systems see Section 10.

**2.15 SAMPLING:** Contact BWD Engineering at 604-789-2204 or Eljen Corporation and 800-444-1359 for more information on sampling devices and techniques that can be used with the GSF system.

### 2.16 SYSTEM COMPONENT SIZING:

**TABLE 2: STANDARD GSF A42 SIZING TABLE - RESIDENTIAL APPLICATIONS**

Bedrooms					
1	2	3	4	5	6
Standard Daily Design Flow Liters/Day					
700	1000	1300	1600	1900	2200
Recommended Minimum Number of Modules					
10	14	18	24	30	36

Table 2 shows the minimum number of A42 modules required for residential systems up to 6 bedrooms. For other flow rates and number of bedrooms not shown in Table 2, divide the DDF by 72 L/d/module and round up to the next whole number. For residential homes a minimum of 6 modules per bedroom is required. If the DDF divided by 72 L/d/module equals less than 6 modules per bedroom, round up to the minimum number of A42 modules required per bedroom.

Flows indicated in Table 2 are the minimum per the SPM-V3 and do not include additional capacity for larger homes and high flow fixtures. For large or non-residential applications, see Section 10 Commercial Systems and please contact the Eljen Technical Representative, BWD Engineering Inc.

For applications where very large infrequent surging is anticipated, the Eljen GSF can manage the additional flows and remain within treatment specifications for a significant duration. To ensure the correct number of modules are specified and proper soil conditions are assessed, please contact the Eljen Technical Representative, BWD Engineering Inc.

**2.17 INFILTRATIVE SURFACE MODULE SIZING:** To cover the larger infiltrative surface areas required by slower soils, for multi row systems, increase the edge-to-edge separation between runs to a maximum of 90 cm. In a single row system, the Eljen GSF system width can be increased by 60 cm for a total width of 150 cm.

For all systems, the Eljen GSF modules can also be separated by up to 90 cm end-to-end to increase infiltrative surface area or contour length without additional modules. For very slow soils, additional modules may be required.

The smallest footprint per module is: 0.9 m X 1.2 m or 1.1 m<sup>2</sup>

The largest footprint per module is: 1.5 m X 2.1 m or 3.2 m<sup>2</sup>

The Shortest length per module is: 1.2 m

The Longest length per module is: 2.1 m

For assistance with very large, unusual shaped, or multiple infiltrative surface areas, please contact the Eljen Technical Representative, BWD Engineering Inc.

## 2.0 Design and Installation

### 2.18 INFILTRATIVE SURFACE SIZING:

**TABLE 3: MAXIMUM HLR BASED ON SOIL TYPE (L/DAY/m<sup>2</sup>)**

(SPM-V3 TABLE II-22 COPIED HERE FOR CONVENIENCE)

SOIL TEXTURE GROUP	STRUCTURE AND CONSISTENCE CATEGORY	TYPE 2 (L/DAY/M <sup>2</sup> )
Very or Extremely Gravelly Sands	F or P	65
Gravelly Sands and Coarse Sand	F	65
	P	65
Sand, Loamy Sand	F	60
	P	50
Fine Sands, Loamy Fine Sands, Sandy Loams	F	50
	P	45
	VP	40
Loam, Silt Loam, Silt	F	40
	P	30
	VP	25
Clay Loam, Sandy Clay Loam, Silty Clay Loam	F	25
	P	15
	VP	NA
Sandy Clay, Silty Clay, Clay	F	15
	P	15
	VP	NA

**TABLE 4: MAXIMUM HLLR BASED ON SOIL TYPE (L/DAY/M)**

(SPM-V3 TABLE II-27 COPIED HERE FOR CONVENIENCE)

SOIL TEXTURE GROUP	CATEGORY	SLOPE 0 TO < 5%				SLOPE 5 TO < 10%				SLOPE 10% TO < 15%				SLOPE ≥ 15%			
		SOIL DEPTH BELOW INFILTRATIVE SURFACE (CM)				SOIL DEPTH BELOW INFILTRATIVE SURFACE (CM)				SOIL DEPTH BELOW INFILTRATIVE SURFACE (CM)				SOIL DEPTH BELOW INFILTRATIVE SURFACE (CM)			
		25 – 45	45 – 60	60 – 90	≥ 90	25 – 45	45 – 60	60 – 90	≥ 90	25 – 45	45 – 60	60 – 90	≥ 90	25 – 45	45 – 60	60 – 90	≥ 90
Very or Extremely Gravelly Sands	F or P	150	260	340	400	290	400	400	400	400	400	400	400	400	400	400	400
Gravelly Sands and Coarse Sand	F	85	140	180	250	150	250	330	400	260	400	400	400	360	400	400	400
	P	50	80	110	140	80	140	180	250	140	240	310	400	200	330	400	400
Sand, Loamy Sand	F	45	60	70	90	55	85	110	150	90	140	180	240	120	190	240	340
	P	45	55	70	70	50	60	75	90	60	90	110	140	80	120	150	200
Fine Sands, Loamy Fine Sands, Sandy Loams	F	45	55	70	70	50	60	75	75	60	75	90	100	75	90	110	130
	P	40	45	55	55	45	50	55	60	50	55	60	65	60	65	75	80
	VP	25	30	35	35	25	35	40	40	30	35	40	40	35	45	50	50
Loam, Silt Loam, Silt	F	40	45	55	55	45	50	55	60	50	55	60	65	60	65	75	80
	P	30	35	40	40	35	40	45	45	35	45	50	55	45	50	60	65
	VP	17	22	26	26	19	24	28	28	21	25	30	30	25	30	35	35
Clay Loam, Sandy Clay Loam, Silty Clay Loam	F	30	35	40	40	35	40	45	45	35	45	50	55	45	50	60	65
	P	25	30	35	35	25	35	40	40	30	35	40	40	35	45	50	50
	VP	NA	NA	NA	NA	NA	NA	NA	NA	NA	NA	NA	NA	NA	NA	NA	NA
Sandy Clay, Silty Clay, Clay	F	25	30	35	35	25	35	40	40	30	35	40	40	35	45	50	50
	P	17	22	26	26	19	24	28	28	21	25	30	30	25	30	35	35
	VP	NA	NA	NA	NA	NA	NA	NA	NA	NA	NA	NA	NA	NA	NA	NA	NA

### 3.0 Field Sizing

#### Example 1:

House size: Standard 3 Bedroom  
 Disposal Area Soils: Silt Loam - Favorable  
 Slope: 5% - 10%  
 Infiltrative Vertical Separation: >90 cm

Lookup Daily Design Flow and Minimum Number of Eljen GSF Modules from Table 2.

Bedrooms					
1	2	3	4	5	6
Standard Daily Design Flow Liters/Day					
700	1000	1300	1600	1900	2200
Recommended Minimum Number of Modules					
10	14	18	24	30	36

**Daily Design Flow:** 1300 L/day  
**Minimum Eljen GSF Modules:** 18 modules (For non-standard design flows: DDF / 72 L/day/module)

Lookup Hydraulic Loading Rate from Table 3

SOIL TEXTURE GROUP	STRUCTURE AND CONSISTENCE CATEGORY	TYPE 2 (L/DAY/M <sup>2</sup> )
Loam, Silt Loam, Silt	F	40
	P	30
	VP	25

**Hydraulic Loading Rate:** 40 L/day/m<sup>2</sup>

Lookup Hydraulic Linear Loading Rate from Table 4.

SOIL TEXTURE GROUP	CATEGORY	SLOPE 0 TO < 5%				SLOPE 5 TO < 10%				SLOPE 10% TO < 15%				SLOPE ≥ 15%			
		SOIL DEPTH BELOW INFILTRATIVE SURFACE (CM)				SOIL DEPTH BELOW INFILTRATIVE SURFACE (CM)				SOIL DEPTH BELOW INFILTRATIVE SURFACE (CM)				SOIL DEPTH BELOW INFILTRATIVE SURFACE (CM)			
		25 - 45	45 - 60	60 - 90	≥ 90	25 - 45	45 - 60	60 - 90	≥ 90	25 - 45	45 - 60	60 - 90	≥ 90	25 - 45	45 - 60	60 - 90	≥ 90
Loam, Silt Loam, Silt	F	40	45	55	55	45	50	55	60	50	55	60	65	60	65	75	80
	P	30	35	40	40	35	40	45	45	35	45	50	55	45	50	60	65
	VP	17	22	26	26	19	24	28	28	21	25	30	30	25	30	35	35

**Hydraulic Linear Loading Rate:** 60 L/day/m

#### PRIMARY SOLUTION – MINIMIZE CONTOUR LENGTH

**Calculate Minimum Infiltrative Area:**  $DDF \div HLR = 1300 \text{ L/d} \div 40 \text{ L/d/m}^2 = 32.5 \text{ m}^2$

**Calculate Minimum Contour Length:**  $DDF \div HLR = 1300 \text{ L/d} \div 60 \text{ L/d/m} = 21.7 \text{ m}$

**Calculate Minimum Coverage Required per Module:**  $32.5 \text{ m}^2 \div 18 = 1.8 \text{ m}^2 \text{ per Module}$

1.8 m<sup>2</sup> is less than the maximum coverage of 3.25 m<sup>2</sup> per modules, so no need for additional modules for coverage.

### 3.0 Field Sizing

**Calculate Minimum Width for Minimum Contour Length:**  $32.5 \text{ m}^2 \div 21.7 \text{ m} = 1.5 \text{ m}$

Note: The maximum width per row is 1.5 m, so for the minimum contour length, one row of 18 Eljen GSF Modules will be required.

**Calculate Req'd Minimum Length to fit the Minimum 18 Modules:**

Modules X Length pre module + end sand =  $(18 \times 1.22 \text{ m}) + 0.3 \text{ m} = 22.3 \text{ m}$

Note: 22.3 m is greater than 21.7 m so we can meet minimum contour length without additional modules or extending the minimum length per module, simply increase the final contour length by 0.6 m.

**Final Dimension Layout**

*(Note: System layout and number of rows will vary based on site constraints)*

Contour Length	22.3 m
Infiltrative Area Total Width	1.5 m
Number of Modules	18 (1 row of 18)
Footprint per Module	1.8 m <sup>2</sup> (1.5 m x 1.2 m)
System Area	33.5 m <sup>2</sup>

FIGURE 5: PLAN VIEW – EXAMPLE 1

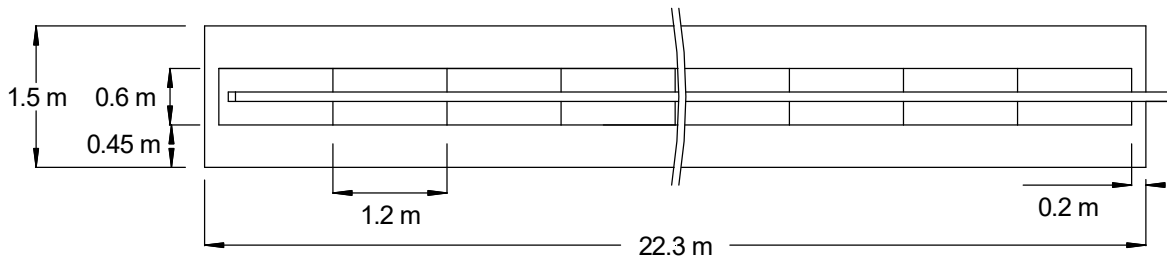
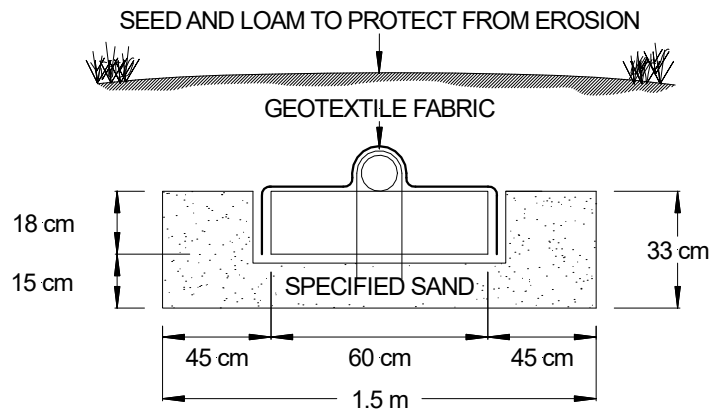

FIGURE 6: SECTION VIEW – EXAMPLE 1



## 3.0 Field Sizing

### Example 2:

House size: Standard 4-Bedroom  
 Disposal Area Soils: Sandy Clay Loam - Favorable  
 Slope: >15%  
 Infiltrative Vertical Separation: >90 cm

Lookup Daily Design Flow and Minimum Number of Eljen GSF Modules from Table 2.

Bedrooms					
1	2	3	4	5	6
Standard Daily Design Flow Liters/Day					
700	1000	1300	1600	1900	2200
Recommended Minimum Number of Modules					
10	14	18	24	30	36

**Daily Design Flow:** 1600 L/day  
**Minimum Eljen GSF Modules:** 24 modules (For non-standard design flows: DDF / 72 L/day/module)

Lookup Hydraulic Loading Rate from Table 3.

SOIL TEXTURE GROUP	STRUCTURE AND CONSISTENCE CATEGORY	TYPE 2 (L/DAY/M <sup>2</sup> )
Clay Loam, Sandy Clay Loam, Silty Clay Loam	F	25
	P	15
	VP	NA

**Hydraulic Loading Rate:** 25 L/day/m<sup>2</sup>

**Calculate Minimum Infiltrative Area Required:** 1600 ÷ 25 = 64 m<sup>2</sup>

Lookup Hydraulic Linear Loading Rate from Table 4.

SOIL TEXTURE GROUP	CATEGORY	SLOPE 0 TO < 5%				SLOPE 5 TO < 10%				SLOPE 10% TO < 15%				SLOPE ≥ 15%			
		SOIL DEPTH BELOW INFILTRATIVE SURFACE (CM)				SOIL DEPTH BELOW INFILTRATIVE SURFACE (CM)				SOIL DEPTH BELOW INFILTRATIVE SURFACE (CM)				SOIL DEPTH BELOW INFILTRATIVE SURFACE (CM)			
		25 - 45	45 - 60	60 - 90	≥ 90	25 - 45	45 - 60	60 - 90	≥ 90	25 - 45	45 - 60	60 - 90	≥ 90	25 - 45	45 - 60	60 - 90	≥ 90
Clay Loam, Sandy Clay Loam, Silty Clay Loam	F	30	35	40	40	35	40	45	45	35	45	50	55	45	50	60	65
	P	25	30	35	35	25	35	40	40	30	35	40	40	35	45	50	50
	VP	NA	NA	NA	NA	NA	NA	NA	NA	NA	NA	NA	NA	NA	NA	NA	NA

**Hydraulic Linear Loading Rate:** 65 L/day/m

**Calculate Minimum Contour Length:** 1600 ÷ 65 = 24.6 m

## 3.0 Field Sizing

### PRIMARY SOLUTION – MINIMIZE CONTOUR LENGTH

**Calculate Minimum Coverage Required per Module:**  $64 \text{ m}^2 \div 24 = 2.7 \text{ m}^2$  per Module

2.7 m<sup>2</sup> is less than the maximum coverage of 3.25 m<sup>2</sup> per modules, so no need for additional modules for coverage.

**Calculate Minimum Width for Minimum Contour Length:**  $64 \text{ m}^2 \div 24.6 = 2.6 \text{ m}$

Note: The maximum width per row is 1.5 m, so for the minimum contour length, two rows of 12 Eljen GSF Modules will be required.

**Calculate the Required Width per Row:**  $2.6 \text{ m} \div 2 = 1.3 \text{ m}$

We need to determine if we need more modules to satisfy the minimum contour length (HLLR) requirement or if we need more length to fit in the minimum 2 rows of 12 modules.

**Calculate Req'd Minimum Length to fit the Minimum 12 Modules:**  $(12 \times 1.22 \text{ m}) + 0.3 \text{ m} = 14.9 \text{ m}$

14.9 m is less than 24.6 m so we can meet minimum contour length.

**Calculate Required Specified Sand Length to meet minimum contour length:**  $24.6 \text{ m} \div 12 = 2.1 \text{ m}$

A single module can cover a length of 2.13 m, so there is no need to add modules, just increase each module system length to 2.1 m.

#### Final Dimension Layout

*(Note: System layout and number of rows will vary based on site constraints)*

Countour Length	24.6 m
Infiltrative Area Total Width	2.6 m
Number of Modules	24 (2 rows of 12)
Footprint per Module	2.73 m <sup>2</sup> (1.3 m x 2.1 m)
System Area	64 m <sup>2</sup>

FIGURE 7: PLAN VIEW – EXAMPLE 2 – OPTION 1 TRENCHES

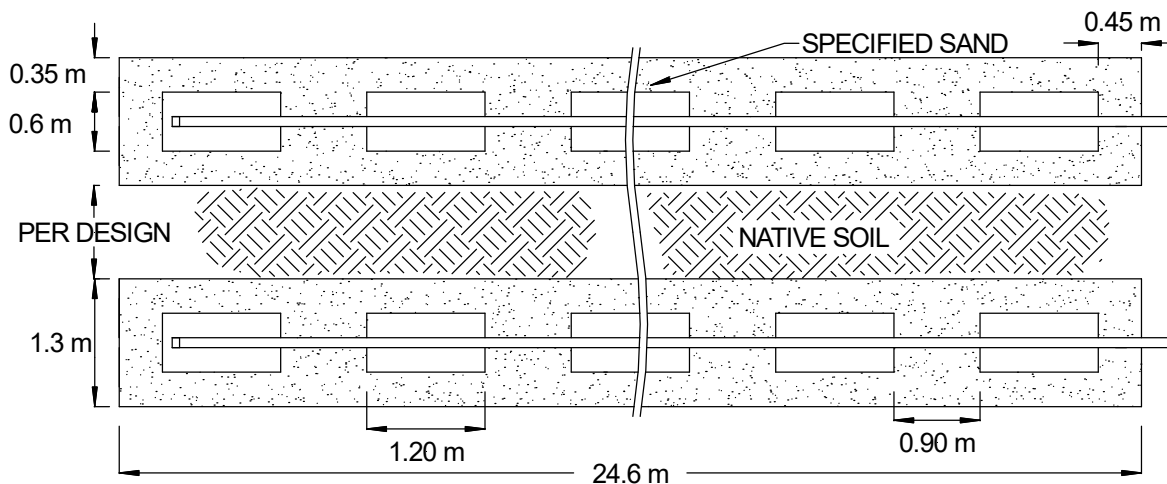



### 3.0 Field Sizing

FIGURE 8: PLAN VIEW – EXAMPLE 2 – OPTION 2 BED

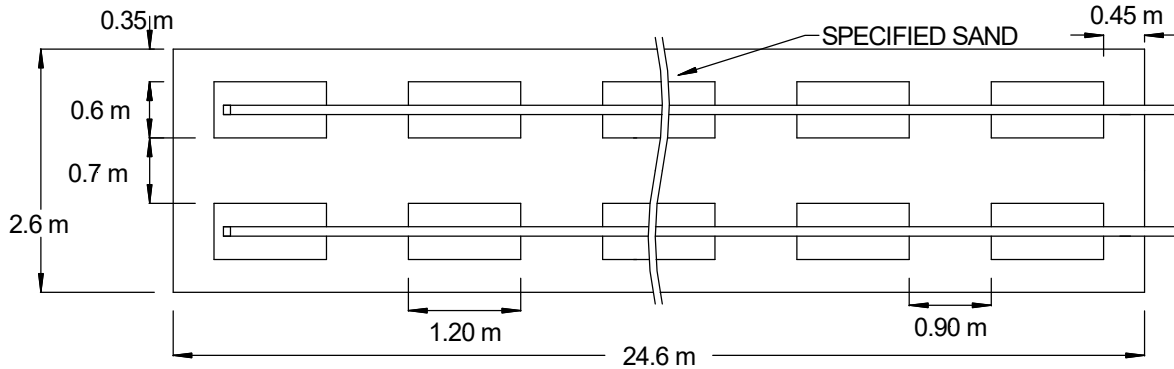

#### **ALTERNATIVE SOLUTION – SINGLE ROW**

**Calculate Contour Length Required at Maximum Width per Single Row:**  $64 \text{ m}^2 \div 1.5 \text{ m} = 42.7 \text{ m}$

**Calculate Required Specified Sand Length per module to meet contour length:**  $42.7 \text{ m} \div 24 = 1.8 \text{ m}$

1.8 m is less than the maximum length of 2.1 m per modules, so no need for additional modules for length.

#### **Final Dimension Layout – Alternate Solution**

*(Note: System layout and number of rows will vary based on site constraints)*

Length	42.7 m
Width	1.5 m
Number of Modules	24 (1 row of 24)
Footprint per Module	2.7 m <sup>2</sup> (1.5 m x 1.8 m)
System Area	64 m <sup>2</sup>

FIGURE 9: PLAN VIEW – EXAMPLE 2 - ALTERNATIVE SOLUTION

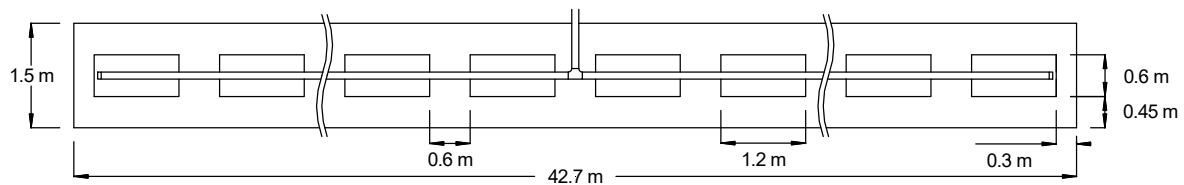

## 4.0 Additional Figures

FIGURE 10: SECTION VIEW – TRENCH SYSTEM – MULTIPLE LATERALS

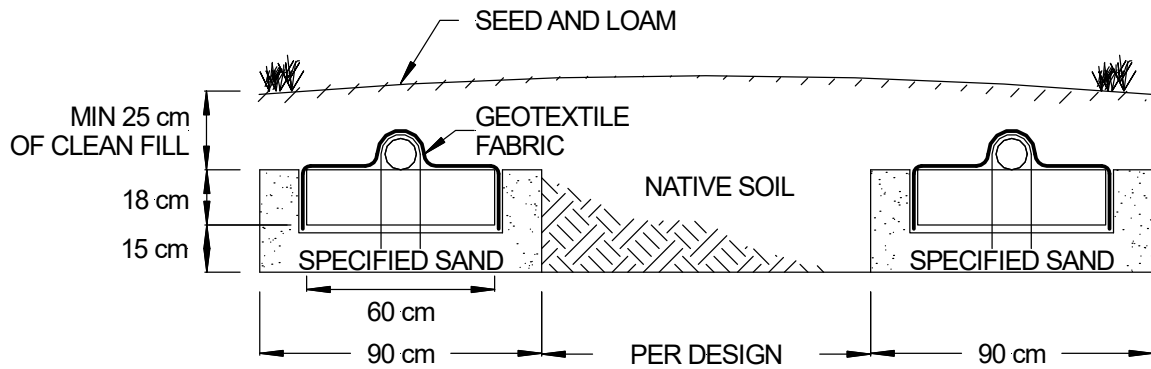

FIGURE 11: SECTION VIEW – TRENCH SYSTEM – SLOPING SITE

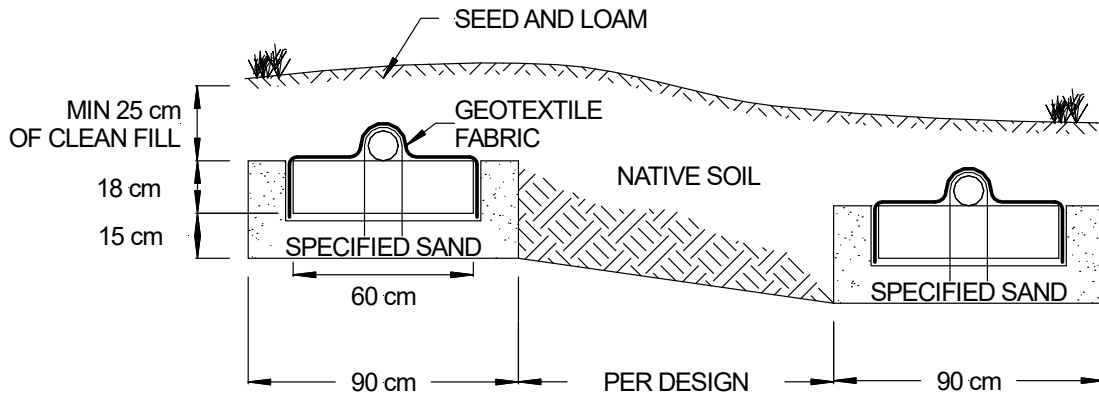
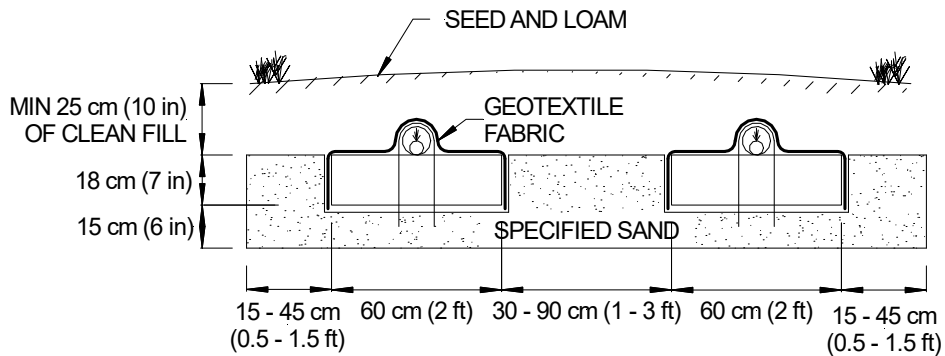
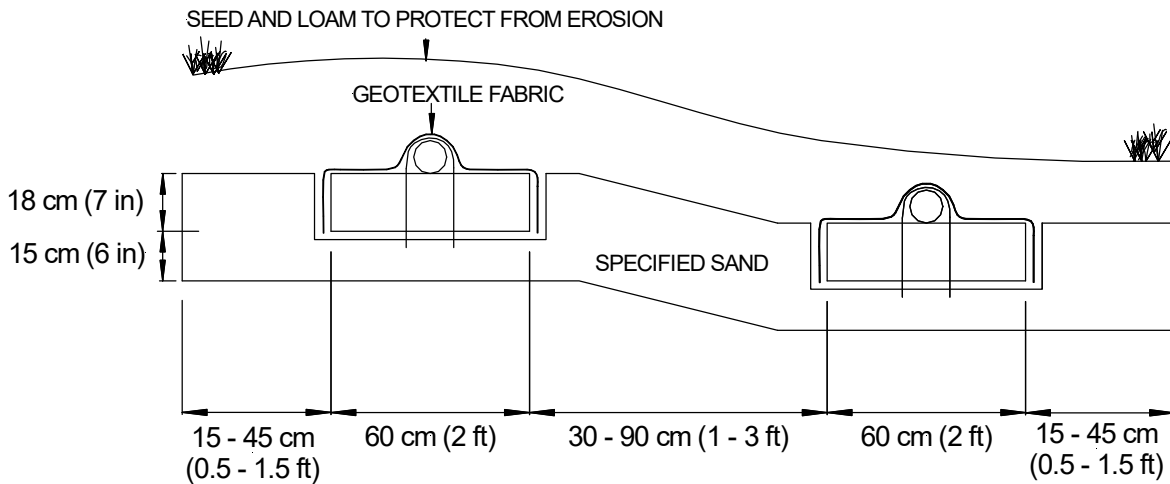

FIGURE 12: SECTION VIEW – BED SYSTEM EXAMPLE



## 4.0 Additional Figures

FIGURE 13: SECTION VIEW – 2 LATERAL BED SYSTEM; SLOPING SITE



Note: If the drop is over 15 cm (6 in), use two times the elevation drop as minimum spacing between module rows. Rows can be separated by up to 90 cm (3 ft) to increase effective infiltrative area (widthwise).

FIGURE 14: A42 RAISED BED (SAND MOUND) CROSS SECTION

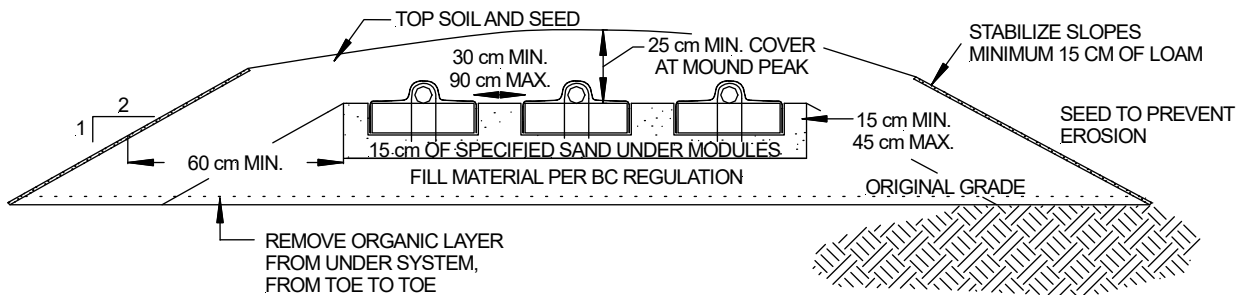
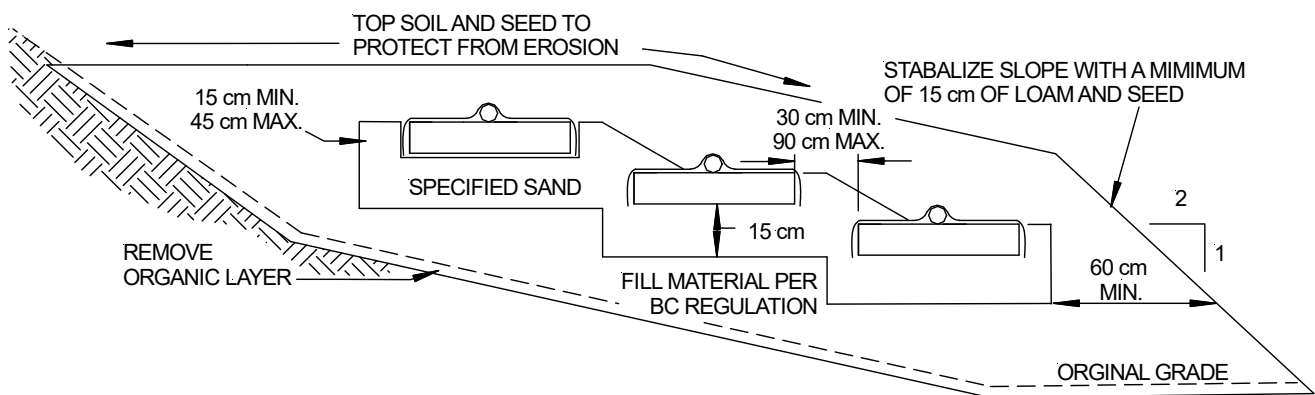

FIGURE 15: RAISED BED ON SLOPE



Note: If the drop is over 15 cm (6 in), use two times the elevation drop as minimum spacing between module rows. Rows can be separated by up to 90 cm (3 ft) to increase effective infiltrative area (widthwise).

## 5.0 Installation Guidelines

---

1. Ensure all components leading to the GSF system are installed properly. Septic tank effluent filters are strongly encouraged with the GSF system.
2. Determine the number of GSF Modules required using the sizing formula.
3. Prepare the site. Do not install a system on saturated ground or wet soils that are smeared during preparation. Keep machinery off infiltrative areas.
4. Plan all drainage requirements up-slope of the system. Set soil grades to ensure that storm water drainage and ground water is diverted away from the absorption area once the system is complete.
5. Remove the organic soil layer. Prepare the receiving layer to maximize the interface between the native soil and Specified Sand. Minimize walking in the absorption area prior to placement of the Specified Sand to avoid soil compaction.
6. Place fill material meeting SPM-V3 requirements onto the soil interface as you move down the excavated area. If this is done in two steps, bring in the fill material from the up-slope side of the excavation. Place specified sand in a 15 cm (6 in) lift and stabilize by foot, a handheld tamping tool or a portable vibrating compactor. The minimum stabilized height below the GSF module must be level at 15 cm (6 in).
7. Place GSF modules with **PAINTED STRIPE FACING UP**, end to end on top of the specified sand along their 120 cm (4 ft) length.
8. A standard perforated distribution pipe is centered along the module's length. Orifices are set at the 4 & 8 o'clock position.
9. All distribution pipes are secured with manufacturers supplied wire clamps, one per module.
10. Insert a PVC Sch. 40 pressure pipe (size per design and code) into the standard perforated distribution pipe. The pressure pipe orifices are set at the 12 o'clock position as shown in Figure 12. Each pressure lateral will have a drain hole at the 6 o'clock position. Each pressure lateral shall include sweeping cleanouts at the terminal ends and be accessible from grade.
11. **Cover fabric substitution is not allowed.** The installer should lay the Eljen provided geotextile cover fabric lengthwise down the row, with the fabric fitted to the perforated pipe on top of the GSF modules. Fabric should be neither too loose, nor too tight. The correct tension of the cover fabric is set by:
  - a. Spreading the cover fabric over the top of the module and down both sides of the module with the cover fabric draped over the top of the perforated distribution pipe.
  - b. Place shovelfuls of Specified Sand directly over the pipe allowing the cover fabric to form a mostly vertical orientation along the sides of the pipe. Repeat this step moving down the pipe.In applications where modules are spaced end-to-end to increase effective basal area and contour length, each module is to have fabric wrapped at each end and *all perforated holes not discharging at least 15 cm (6 in) onto a GSF module must be sealed.* See Figure 4 for an example.
12. Ensure there is a minimum of 15 cm (6 in) of specified sand surrounding the GSF modules. Slope the sand away from the system as described on the plan.
13. Complete backfill with a minimum of 25 cm (10 in) of cover material measured from the top of the module. Use well graded native soil fill that is clean, porous and devoid of large rocks. Do not use wheeled equipment over the system. A light track machine may be used with caution, avoiding crushing or shifting of pipe assembly.
14. Divert surface runoff from the system. Finish grade to prevent surface ponding. Topsoil and seed system area to protect from erosion.

Note: An installation video is available for viewing at [www.eljen.com](http://www.eljen.com)

## 6.0 Dosing Distribution Guidance

**6.1 PUMP TO DISTRIBUTION BOX:** Specify an oversized distribution box for pumped systems. Provide velocity reduction in the D-box with a tee or baffle. Set D-box invert a minimum of 5 cm higher than invert of perforated pipe over GSF modules. Do not use flow equalizers or other restricting devices in the outlet lines of the D-box. Pump chamber shall be vented.

**6.2 DOSING DESIGN AND FLOW RATE:** Set the floats or pump time controls to deliver a maximum of 10 liters (2.2 IG) per A42 module for each dosing cycle. Additional volume for the effluent draining back to the dose tank must be added to this volume.

**Dose Volume = number of modules x 10 L (2.2 IG) per module + force main volume**

For example, if the system uses 24 modules, set the dose volume at 240 liters plus the volume of effluent in the force main. A 50 mm (2 in) pipe stores 1.963 liters per meter. Using 20 m of 50 mm pipe, the pipe storage volume is 39 liters. This is added to the 240-liter (52.9 IG) dose volume for a sum total of 279 liters per dosing cycle. The addition of the pipe volume assumes the force main is drained between doses.

*Note: When pumping to D-box do not exceed D-box manufacturer's maximum flow rate.*

## 7.0 Pressure Distribution Guidance

**7.1 PRESSURE DISTRIBUTION:** Dosing with small diameter pressurized laterals is acceptable for GSF systems. The pipe networks must be engineered and follow principles established for pressure distribution. Using pipe-in-pipe networks as shown in Figure 17, it is recommended that there is a minimum of one orifice per module. Flushing ports are required to maintain the free flow of effluent from orifices at the distal ends of each lateral. Contact BWD Engineering at 604-789-2204 or Eljen's Technical Resource Department at 1-800-444-1359 for more information on pressure distribution systems.

Standard procedures for design of pressure distribution networks apply to the GSF. A minimum orifice size according to the regulations shall be maintained. A drain hole is required at the 6 o'clock position of each pressure lateral for drainage purposes. The lateral pipe network, constructed of PVC Sch. 40 pipe (*size per design and code*), is placed within a standard 10 cm (4 in) perforated pipe. The perforation in the 10 cm (4 in) outer pipe are set at the 4 and 8 o'clock position, the drilled orifices on the pressure pipe are set to spray at the 12 o'clock position directly to the top of the 10 cm (4 in) perforated pipe as shown below. Pressure clean outs are required at the end of each lateral.

FIGURE 16: PRESSURE PIPE PLACEMENT

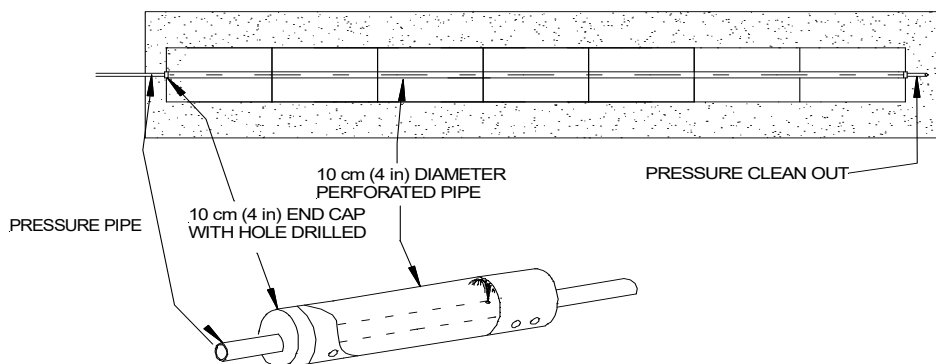

PRESSURE PIPE CROSS SECTION FOR ALL APPLICATIONS

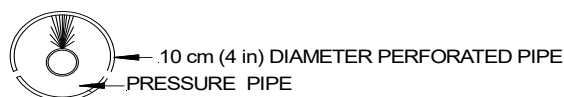

FIGURE 17: PRESSURE CLEAN OUT

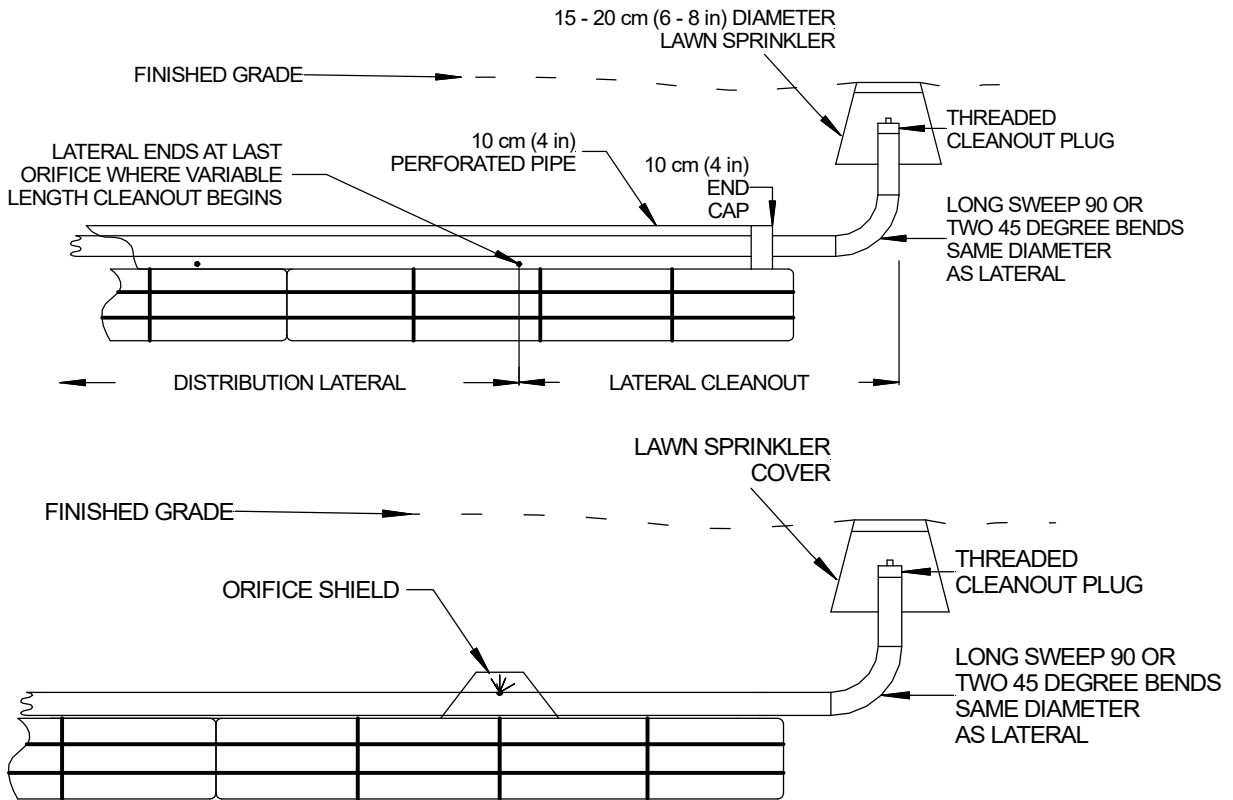
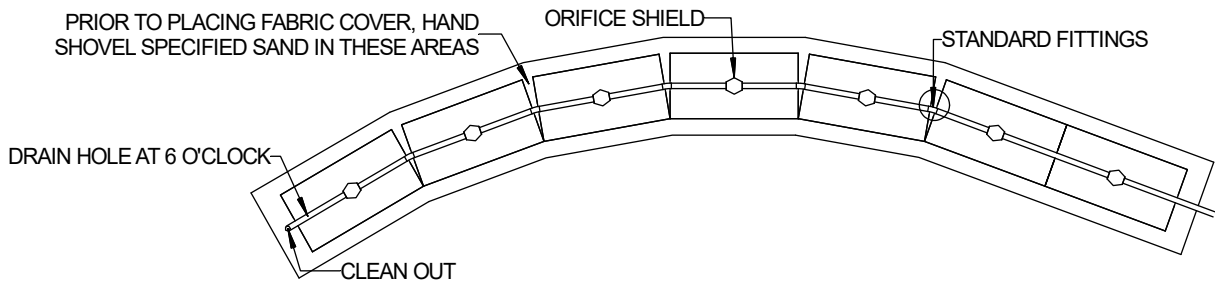

FIGURE 18: CONTOURED TRENCH PRESSURE DISTRIBUTION USING ORIFICE SHIELDS



GSF Pressure Distribution trench placed on a contour or winding trenches to maintain horizontal separation distances.

## 8.0 System Ventilation

**8.1 SYSTEM VENTILATION:** Air vents are only required in dispersal field systems when located under impervious surfaces or systems with more than 45 cm of cover material as measured from the top of the GSF module to finished grade. This will ensure proper aeration of the GSF modules. There are aeration channels connecting to cuspatations within the GSF modules. Under normal operating conditions, only a fraction of the filter is in use. The unused channels remain open for intermittent peak flows and the transfer of air. The extension of the distribution pipe to the vent provides adequate delivery of air into the GSF system, as shown in Figure 22.

Home plumbing operates under negative pressure due to hot water heating the pipes and reducing the density of air in the house vent. As hot air rises and exits the home, it must be replaced by air from the GSF. To maintain this airflow and fully aerate the GSF system, it is important that air vents are located only on the distal end of the GSF pipe network. If the system is specified with greater than 45 cm (18 in) of cover or has impervious cover, an additional 10 cm (4 in) diameter vent line may be extended from the field piping back to the septic tank or the riser on the pump tank as shown in Figure 20. This maintains the continuity of airflow from the field into the house plumbing.

For the GSF system, the vent is a 10 cm (4 in.) diameter pipe extended to a convenient location behind shrubs, as shown in Figure 22. If the vent is extended, the pipe must not drain effluent and must have an invert higher than the system. Elevated systems requiring venting must elevate the first meter of vent line above the top of the GSF with fittings to prevent effluent from migrating down the vent. The vent can then be pitched away from the system to a discrete area. A drain hole must be installed at the lowest point to drain any condensation.

**8.2 AIR BY-PASS LINE:** Air by-pass lines are required for pressurized systems with greater than 45 cm (18 in) of cover of the modules. This promotes the movement of air from the vents back to the high vent in the home or business. This is accomplished by connecting an air by-pass line to a footer on the system that has a vent and plumbing it back into the pump chamber or septic system.

FIGURE 19: AIR BY-PASS LINE DETAIL FOR VENTING OF PUMPED SYSTEMS (WHEN REQUIRED)

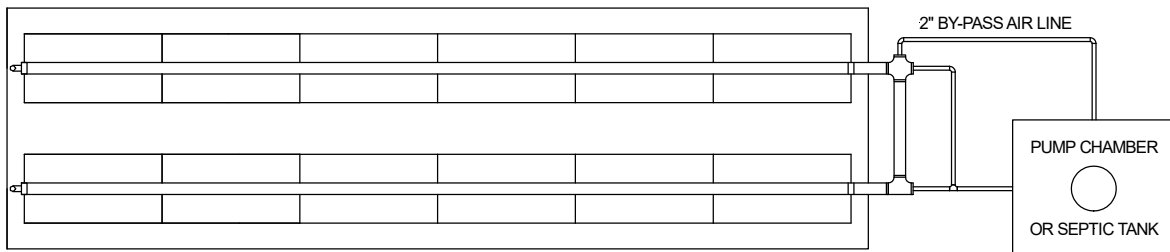

## 8.0 System Ventilation

**8.3 VENT PIPE FOR LOW PRESSURE SYSTEMS:** Systems with over 45 cm of cover over the top of the modules require a vent. If the system is a low-pressure distribution system, ensure that the LPP clean outs are located in the vent for easy access.

FIGURE 20: VENT LAYOUTS FOR LOW PRESSURE SYSTEMS

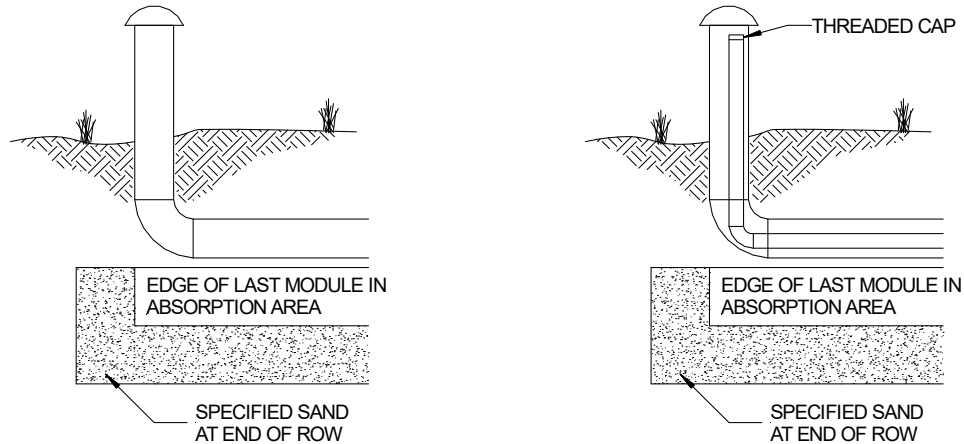

**8.4 VENTILATION PLACEMENT:** In a GSF system, the vent is usually a 10 cm (4 in) diameter pipe extended to a convenient location behind shrubs, as shown in the figure below. Corrugated pipe may be used. If using corrugated pipe, ensure that the pipe does not have any bends that will allow condensation to pond in the pipe. This may close off the vent line. The pipe must have an invert higher than the system so that it does not drain effluent.

FIGURE 21: GSF WITH 4" VENT EXTENDED TO CONVENIENT LOCATION

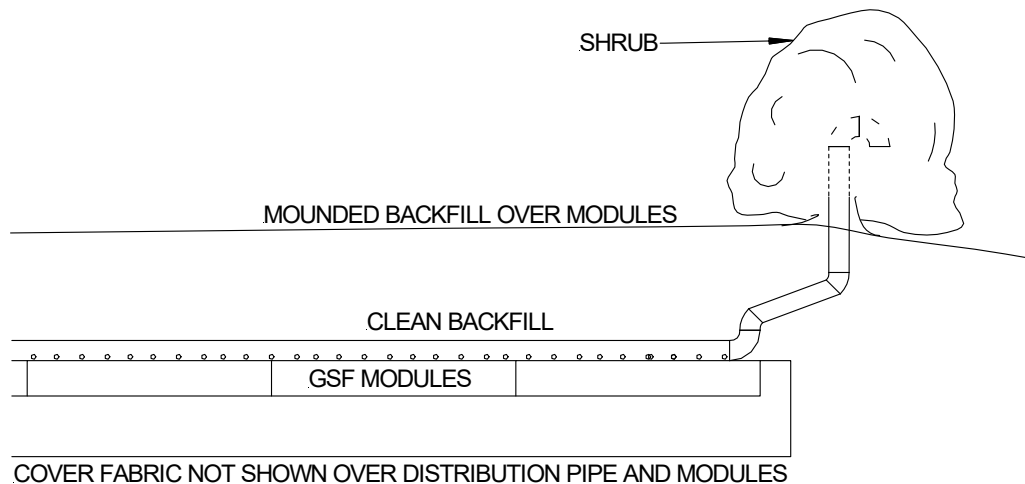



## 9.0 Required Notes on Design Plans

---

1. This system (IS/IS NOT) designed for the use of a garbage disposal.
2. This system is NOT designed for backwash from a water softener.
3. This system is NOT designed for condensate from a high-efficiency furnace.
4. This system IS design for \_\_\_\_\_ wastewater only.
5. Organic Loam Layer must be removed from bed and slope extension areas prior to fill placement. Scarify subsoil prior to fill placement.
6. All fill material shall meet SPM-V3 requirements. The 15 cm of Specified System Sand underneath and surrounding the GSF modules shall be concrete sand meeting the requirements of ASTM C33 with less than 10% passing a #100 sieve and less than 5% passing a #200 sieve.
7. Backfill material can be suitable soil with no stones larger than 5 cm in any dimension to a minimum depth of 25 cm over the top of the distribution pipe.
8. Any system that is more than 45 cm below finish grade as measured from the top of the module shall be vented.
9. This design complies with and must be installed in accordance with the March 2024 Eljen GSF Design and Installation Manual for British Columbia.  
With the following exceptions: (List any exceptions here)

## 10.0 Commercial Recommendations and Guidance

---

Commercial systems differ from residential systems relative to wastewater characteristics, effluent distribution strategies, peak flows, system size and geometry. As these systems are normally larger, the designer must also consider the collection systems and their integrity, groundwater hydrology, drainage above and below the GSF system and design accordingly.

Designers should carefully review and document with their client effluent BOD<sub>5</sub> and TSS concentrations and water use numbers. The designer should document that the system installation meets the technology supplier's specifications to ensure long-term performance. In addition, designers must be attentive to special details of the system, conduct follow-through startup and document technical capabilities for personnel required for Operation and Maintenance of the system.

To determine design flow for commercial systems, with the exception that the highest measured single day flow in a 12-month period shall not result in a design flow less than the measured average flow with a peaking factor of 2 to 3 depending on the type of usage.

A variety of wastewater delivery options exists and includes pressure distribution, pressure dosing, and gravity dispersed type systems. Wastewater volume and strength, systems size, and site conditions often dictate which type of system is designed. Designers should confer with the local permitting authority as many jurisdictions mandate pressure distribution or pressure dosing when daily wastewater flow exceeds certain levels.

Designers must also consider how the distribution of the effluent onto the GSF modules may affect the linear loading rates and allow for the means to adjust the linear loading should the soils fail to move the effluent as predicted. Longer systems are naturally preferred as this geometry reduces the linear loading and the risk of hydraulic overload with surfacing of treated effluent down slope in serial type systems.

Extremely large systems should be designed as several smaller systems allowing for independent management of the wastewater treatment system. Designs typically include valves to rotate zones into service with access to flow diversion boxes. Management plans are frequently implemented for monitoring the fluid levels and adjusting the effluent application onto the geotextile filter modules.

Larger flow groundwater recharge systems can be impacted by site drainage from above the GSF. The additional water can also increase the groundwater mound down slope. Recharge systems such as the GSF must be designed and located so that they can accept precipitation and the specified wastewater volume. Control and diversion of up-slope stormwater is normally included in the design. Understanding the stormwater flows onto and out of the system is essential to successful management of these systems.

Landscape position and slope impact the drainage because the gradient frequently changes with the slope of the land, especially if placed above a restrictive layer. The depth and permeability of each soil layer above the restrictive horizon impacts the groundwater mound. For example, upper horizons may be fairly permeable and accept precipitation easily. If these layers are above a more restrictive horizon, a perched water table will develop whenever it rains. Movement of this perched groundwater can influence the disposal system and if not recognized will result in surfacing effluent. Interception and diversion of the groundwater is therefore necessary with larger systems especially over restrictive soils to insure acceptance of the treated effluent under wet conditions.

Down slope hydraulic capacity is also an important consideration with larger systems. For example, a system may be located on a free draining slope, but down slope conditions show a perched water table due to a reduced hydraulic gradient. Design limits and linear loading must be considered, and these limits should be based on the limitations of these down slope soils and gradient. Ideally systems are located with diverging topography that reduces the linear loading and results in the effluent moving down slope.

## 10.0 Commercial Recommendations and Guidance

---

System owners should educate occupants in the operation and maintenance of the system to help ensure long term system performance. The state or local permitting authority should provide for site specific items and require inspection and evaluation of an overall operating plan as commercial systems can produce flows in the thousands of gallons per day range. Designers should also provide oversight of system installation and associated system equipment.

BWD Engineering Inc. (604-789-2204), Eljen Corporation's Western Canada Technical Representative, is available for a no cost review of any commercial GSF plan prior to submission for approval from the local approving authority. Overall responsibility for system design remains with the licensed designer and/or professional.

## **COMPANY HISTORY**

Established in 1970, Eljen Corporation created the world's first prefabricated drainage system for foundation drainage and erosion control applications. In the mid-1980s, we introduced our Geotextile Sand Filter products for the passive advanced treatment of onsite wastewater in both residential and commercial applications. Today, Eljen is a global leader in providing innovative products and solutions for protecting our environment and public health.

## **COMPANY PHILOSOPHY**

Eljen Corporation is committed to advancing the onsite industry through continuous development of innovative new products, delivering high quality products and services to our customers at the best price, and building lasting partnerships with our employees, suppliers, and customers.



90 Meadow Road, Windsor, CT 06095 • Tel: 800-444-1359 • Fax: 860-610-0427

**[www.eljen.com](http://www.eljen.com)**

